

1906-3H1909

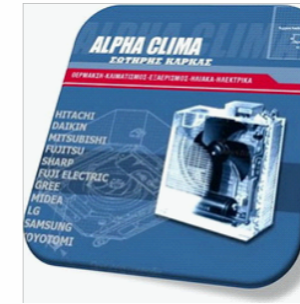

Commercial Air Conditioners 2019



M-Thermal Heat Pumps Mono/Split

Commercial Air Conditioner Division Midea Group

Add.: Midea Headquarters Building, 6 Midea Avenue, Shunde, Foshan, Guangdong, China

Postal code: 528311

cac.midea.com global.midea.com



Note: Product specifications change from time to time as product improvements and developments are released and may vary from those in this document.

MIDEA participates in the ECP programme for VRF with diploma no.16.05.007. Check ongoing validity of certification: www.eurovent-certification.com.



Midea CAC

Midea CAC is a key division of the Midea Group, a leading producer of consumer appliances and provider of heating, ventilation and air conditioning solutions. Midea CAC has continued with the tradition of innovation upon which it was founded, and emerged as a global leader in the HVAC industry. A strong drive for advancement has created a groundbreaking R&D department that has placed Midea CAC at the forefront of a competitive field. Through these independent efforts and joint cooperation with other global enterprises, Midea has supplied thousands of innovative solutions to customers worldwide.

There are three production bases: Shunde, Chongqing and Hefei.

MCAC Shunde: 38 product lines focusing on VRF, Split Products, Heat Pump Water Heaters, and AHU/FCU.

MCAC Chongqing: 14 product lines focusing on Water Cooled Centrifugal/Screw/Scroll Chillers, Air Cooled Screw/Scroll Chillers, and AHU/FCU.

MCAC Hefei: 11 product lines focusing on VRF, Chillers, and Heat Pump Water Heaters.



MIDEA GROUP
FORTUNE GLOBAL
FORTUNE
500

- 2018-2019 >> Launched the new generation of R32 M-Thermal products, including Mono and Split type.
- 2016 >> Acquired 80% stake in Clivet.
 - Launched the new generation of R410A M-Thermal products, including Mono and Split type.
- 2015 >> JV with Carrier in China in chiller field, BOSCH in VRF production and Siix in smart control.
- 2013 >> Launched combo type 300L products with enamel water tank.
- 2012 >> Introduced the professional production line EISENMAN from German.
- 2011 >> Launched the first generation of M-thermal products.
- 2010 >> Built the 3rd manufacturing base in Hefei.
- 2008 >> Launch the first generation of combo type products.
- 2007 >> Cooperated with GE to develop combo type air source heat pump.
- 2004 >> Launch the first generation of direct heating products.
- 2003 >> Entered the air source heat pump field and launched the first generation cycle heating products.
- 1999 >> Entered the CAC field.

Contents

- ❖ 04 Introduction
- ❖ 07 DC Inverter Technology
- ❖ 09 Overview
- ❖ 13 Features
- ❖ 22 Typical Applications
- ❖ 34 Specifications



Introduction

Why choose an air source heat pump?



Typically around 3kWh of energy can be captured for every 1kWh of electrical energy expended, giving almost 4kWh of heat energy for only 1kWh of electrical input and giving efficiency of almost 400%.

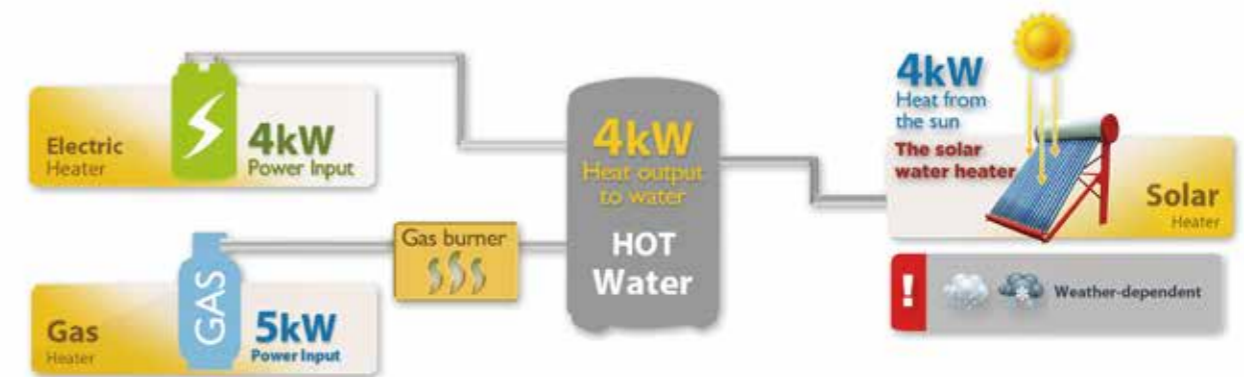

Comparison of energy sources

	Midea air source heat pump	Gas boiler	Electric water Heater	Diesel boiler	Solar water heater
Energy source	Air and electricity	LPG	Electric	Diesel	Sun and electricity
Calorific value	860kcal/kWh	24000kcal/m ³	860kcal/kWh	10200kcal/kg	860kcal/kWh
Average efficiency	4.0	0.8	0.95	0.7	2.7
Consumption*	11.63kWh	2.09m ³	48.96kWh	5.6kg	17.22kWh
Running cost(USD)	0.9	5.9	4.3	6.5	1.5

LPG: Liquefied Petroleum Gas

1. Products tested under controlled conditions at Midea laboratories.
2. * 40,000kcal are required to heat 1 ton of water from 15°C to 55°C.

How air source heat pump works

M-Thermal heat pump units are capable of extracting heat from the surrounding air and transferring this heat indoors for space heating and domestic hot water. For space cooling, M-Thermal can reverse the process and remove heat from the indoor air.



1 Stage One

As the refrigerant passes through the expansion valve and expands, its temperature and pressure both drop. Refrigerant R32 does not freeze even though the temperature is very low.

2 Stage Two

With the temperature of the refrigerant being lower than the ambient temperature, heat passes from the air flowing over the air side heat exchanger to the refrigerant and the refrigerant evaporates.

3 Stage Three

When the refrigerant vapor passes through the compressor its pressure increases and its temperature rises above that of the water in M-Thermal's hydronic system.

4 Stage Four

As the hot vapor refrigerant passes through the water side heat exchanger it heats the water in the hydronic system, which is then pumped indoors to the space heating terminals and domestic hot water tank. The refrigerant cools and condenses and is then ready to return to the expansion valve to start the cycle again.

Total heat solution - Heating, cooling and domestic hot water in one system

M-Thermal is an integrated system that provides space heating and cooling as well as domestic hot water, offering a complete, all-year-round solution which can remove the need for traditional gas or oil boilers, or work together with them.

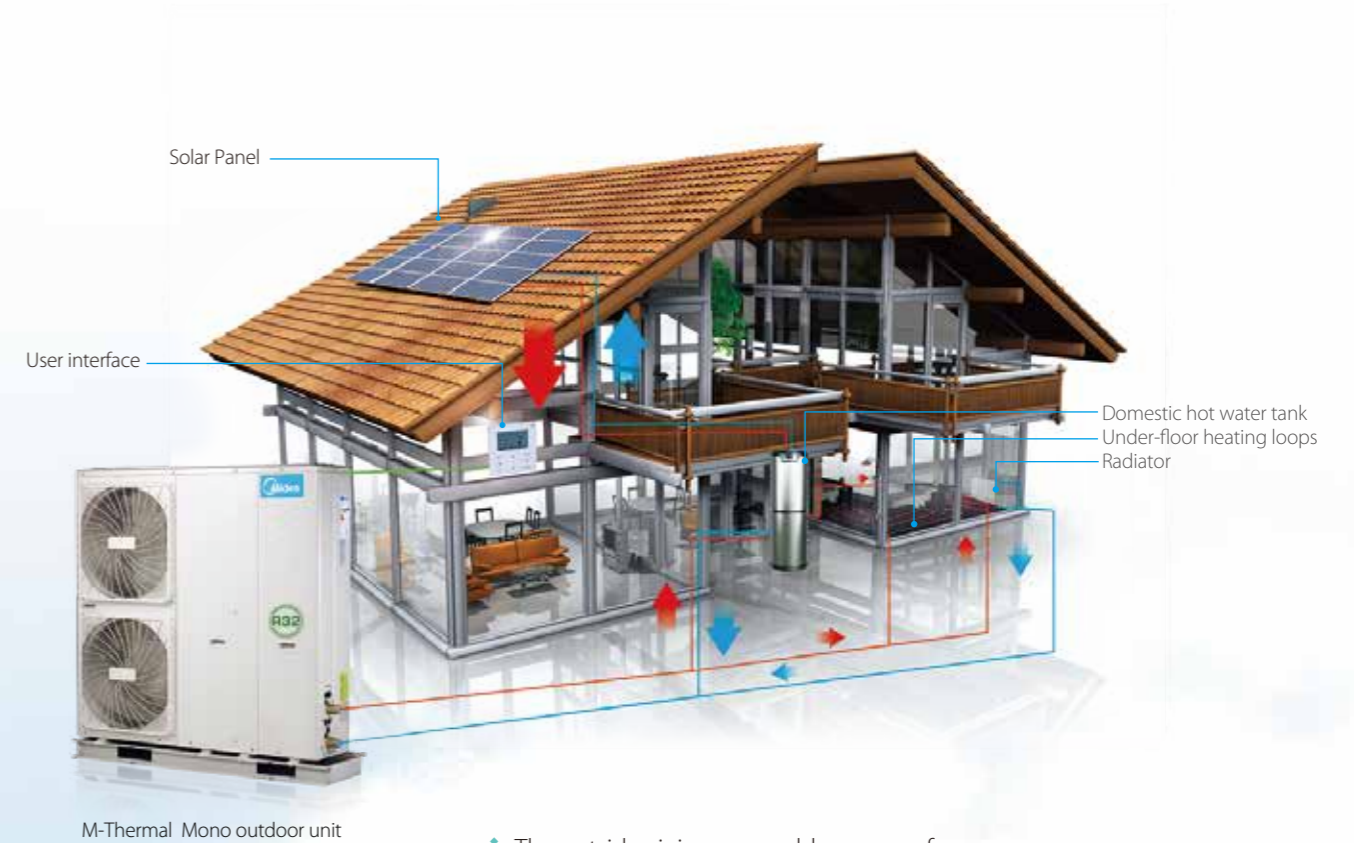

- ❖ The outside air is a renewable source of energy
- ❖ DC inverter technology enables high energy efficiency
- ❖ Sufficient heating capacity at low ambient temperatures (even at -25°C)
- ❖ Provide space heating, cooling and domestic hot water, total heat solution
- ❖ Compatible with other heat sources such as solar panels and boilers



DC Inverter Technology

The motors traditionally used in heat pumps run at full power even during part-load operation, wasting energy. Midea's M-Thermal products use DC inverter technology, which allows precise control of motor speed, ensuring that only the power necessary to perfectly match the real load is used.

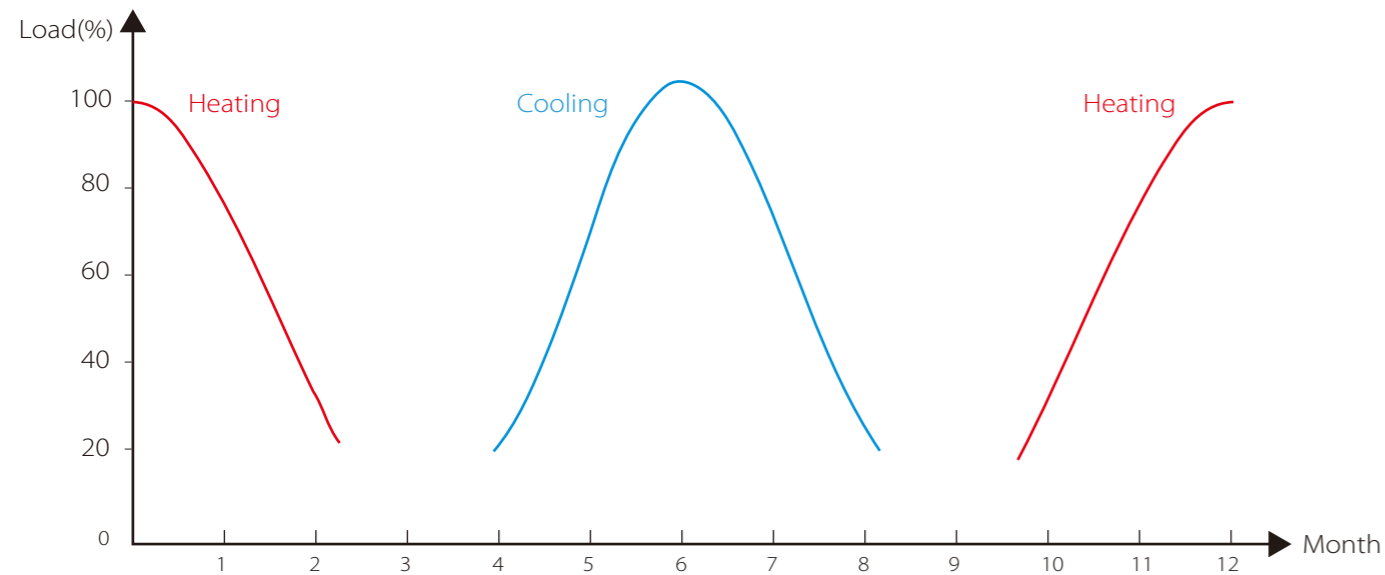

High energy efficiency

Twin rotary DC inverter compressor uses 30% less power than traditional scroll compressors whilst also giving a wider operating frequency range, enabling precise control and reducing running noise levels.

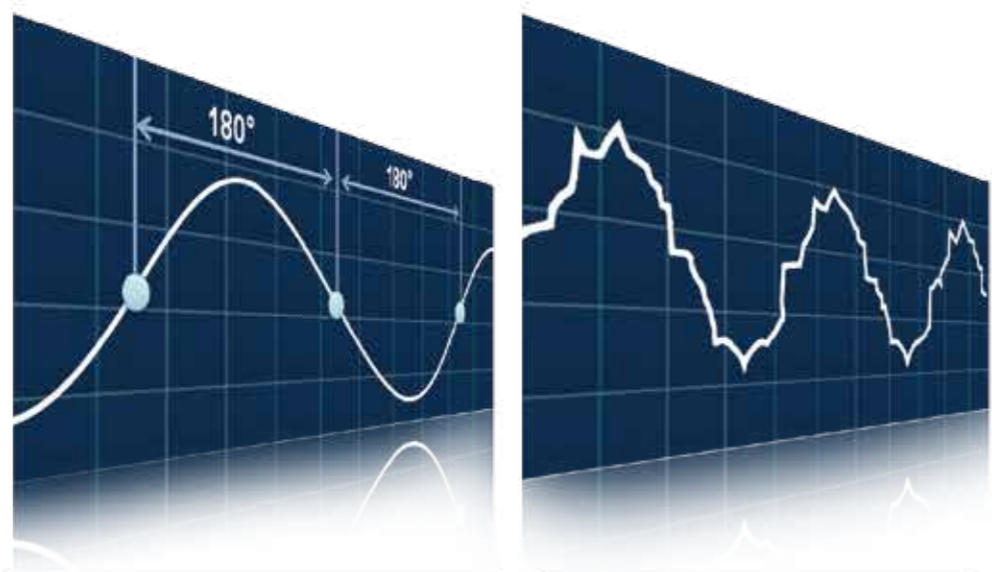

Smooth sine wave improves efficiency by around 30% compared to conventional saw tooth wave

Stable water temperature improves comfort

Precise control of the compressor rotation speed ensures that the water temperature is maintained within a much smaller range around the set temperature than is possible with non-inverter systems.

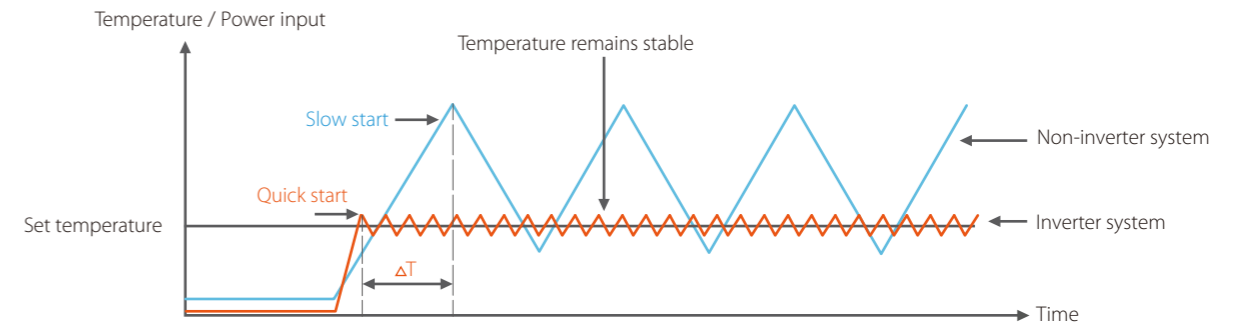

Quick start-up

Inverter system output power according to the energy demand by adjusting motor rotary frequency, so it possible to achieve comfort conditions in less time than system without inverter, start-up time reduced.

Less frequent start/stop

The ability to vary compressor speed (as opposed to simple on/off control) means that the compressors experience fewer start/stop cycles which expands compressor lifespan and reduces noise.

Quiet operation

Most of the time, the capacity required for heating/cooling is lower than the peak load condition, meaning that heat pumps work under part-load conditions most of the time. With DC inverter compressors adjusting rotation speed according to the actual load requirement, noise levels are lower than with traditional compressor technology.



Overview

The M-Thermal range offers the flexibility to either have the hydronic components installed indoors or outdoors. With M-Thermal Mono, the hydronic components are integrated into the outdoor unit, offering ease of installation, whilst with M-Thermal Split the hydronic components are contained in a separate hydronic box, offering more installation flexibility. Both the Mono and Split products are rated A+++ on the energy efficiency and make a significant contribution to limiting the impact on the environment.



Product lineup

M-Thermal Mono

Capacity(kW)	5	7	9	12	14	16
Appearance						
220~240V-1Ph	●	●	●	●	●	●
380~415V-3Ph				●	●	●

M-Thermal Split

Capacity(kW)	4	6	8	10
Appearance				
220~240V-1Ph		● ●	● ●	

● Outdoor unit ● Hydronic box (4-6kW) ● Hydronic box (8-10kW)

Nomenclature

Outdoor units

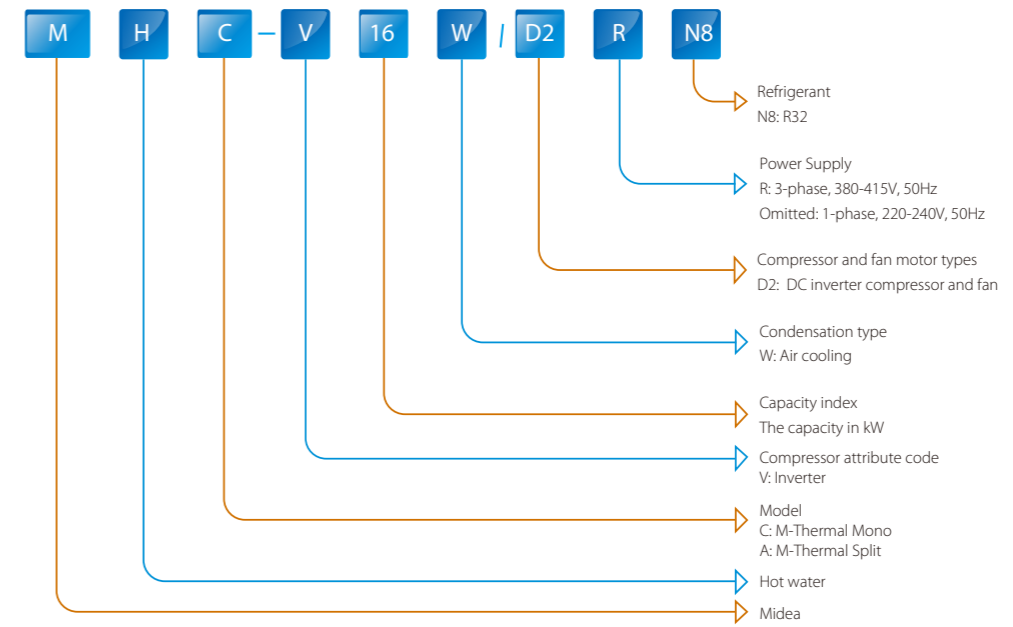

Hydronic box

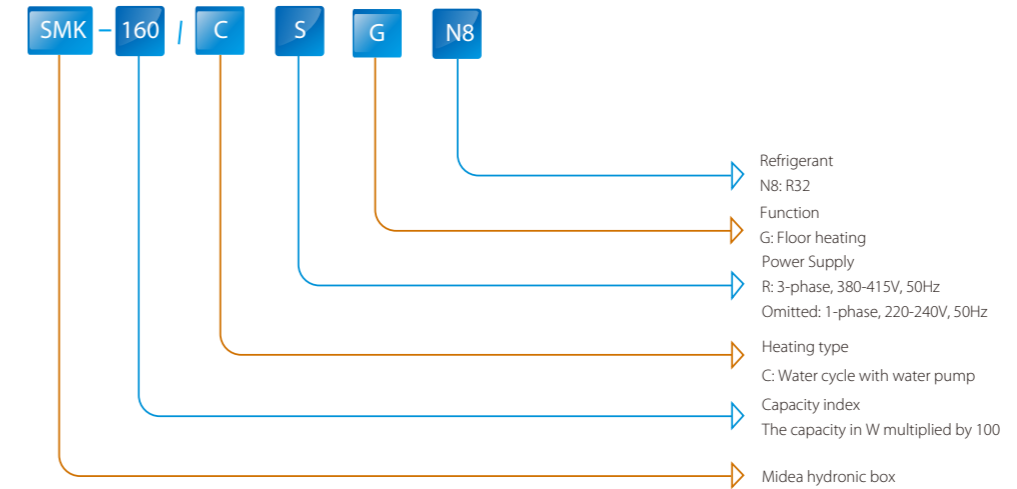

R32 Refrigerant



- ❖ Low GWP and carbon emission
- ❖ Better performance under severe conditions
- ❖ Less charged volume is needed in the system
- ❖ Lowcost and higher coefficient of heat transfer

Abbreviations:

GWP: Global warming potential

M-Thermal Mono

M-Thermal Mono System		
	Application	Heating + Cooling + Domestic hot water
	Structure type	Integrated (Heat pump and hydronic box are in the same casing)
	Refrigerant piping	Inside outdoor unit
	Water piping	Between outdoor unit and indoor heating appliances
	Installation	Only need to install water piping
	Combinational parts (field supplied)	<ul style="list-style-type: none"> Under-floor heating coils Fan coil units Low temperature radiators Domestic hot water tank Auxiliary heat sources (such as water heaters and boilers)

Mono outdoor unit

Mono outdoor unit absorbs heat from the outside air and transfers it to the water in the hydronic modular, through water to supply heat to indoor side.

Domestic hot water tank

Hot water from the Mono unit is circulated around the domestic hot water tank's heating water coil, heating the domestic hot water inside the tank. Immersion heaters are often installed in domestic hot water tanks as a backup.

User interface

User interface is connected to the Mono unit through signal wire; it mainly uses for ON/OFF the unit, mode setting, temperature adjusting and timer setting.

M-Thermal Split

M-Thermal Split System		
	Application	Heating + Cooling + Domestic hot water
	Structure type	Split (Heat pump and hydronic box are independent)
	Refrigerant piping	Between heat pump unit (outdoor) and hydronic box (indoors)
	Water piping	Between hydronic box and indoor heating appliances
	Installation	Refrigerant piping and water piping
	Combinational parts (field supplied)	<ul style="list-style-type: none"> Under-floor heating loops Fan coil units Low temperature radiators Domestic hot water tank Auxiliary heat sources (such as water heaters and boilers)

Split type outdoor unit

The outdoor unit absorbs heat from the outside air and transfers it inside through the refrigerant piping.

Hydronic box

The hydronic box heats the water by refrigerant from outdoor unit. The heated water circulates through heating apparatus such as floor heating, radiators, fan coil units as well as inner coil of domestic hot water tank.

Domestic hot water tank

Hot water from the Split unit is circulated around the domestic hot water tank's heating water coil, heating the domestic hot water inside the tank. Immersion heaters are often installed in domestic hot water tanks as a backup.

User interface

User interface is connected to the Split unit through signal wire. It mainly uses for ON/OFF the unit, mode setting, temperature adjusting and timer setting.

Features

M-Thermal Mono

High efficiency and wide operating range

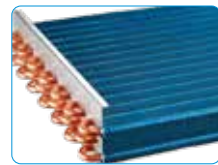

Finned tube heat exchanger
Air side heat exchanger's inner-threaded copper tubing smoothes refrigerant flow to optimize heat exchange efficiency. Hydrophillic coating improves condensate drainage, reducing frost accumulation and improving corrosion resistance.



Brushless DC fan motor
Stepless fan motor control enables super-quiet fan operation and minimizes power consumption.

Twin rotary compressor

Twin rotary DC inverter compressor uses 30% less power than traditional scroll compressors whilst also giving a wider operating frequency range, enabling precise control and reducing running noise levels.

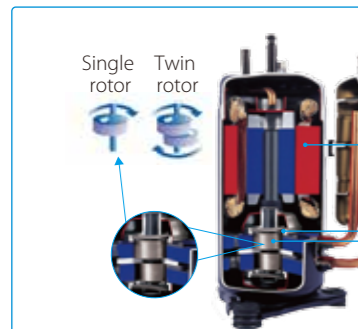

Twin rotary compressor

- High efficiency DC motor:**
- Innovative motor core design
 - High density neodymium magnet
 - Concentrated stator
 - Wide operating frequency range
- Better balance and extremely low vibration:**
- Twin eccentric cams
 - 2 balance weights
- Highly stable moving parts:**
- Optimize compressor drive technology
 - Highly robust bearings
 - Compact structure



Hydronic module
Integrated hydronic module with DC water pump and backup electric heater.



- ❖ Backup electric heater is customizable for additional heating during extremely cold weather. The capacity of the backup electric heater is customizable and the output capacity is adjustable. For MHC-V5(7/9)W/D2N8, the backup electric heater is installed in an optional external box while it is built into MHC-V12(14/16)W/D2(R)N8.
- ❖ Heating, cooling and domestic hot water: a total heat solution.
- ❖ Compatible with additional heat sources (AHSs) including solar water heaters and boilers. AHSs can work together with heat pump or alternative for space heating and domestic hot water dependent on the system control.
- ❖ Wide ambient temperature and water outlet temperature operation ranges.

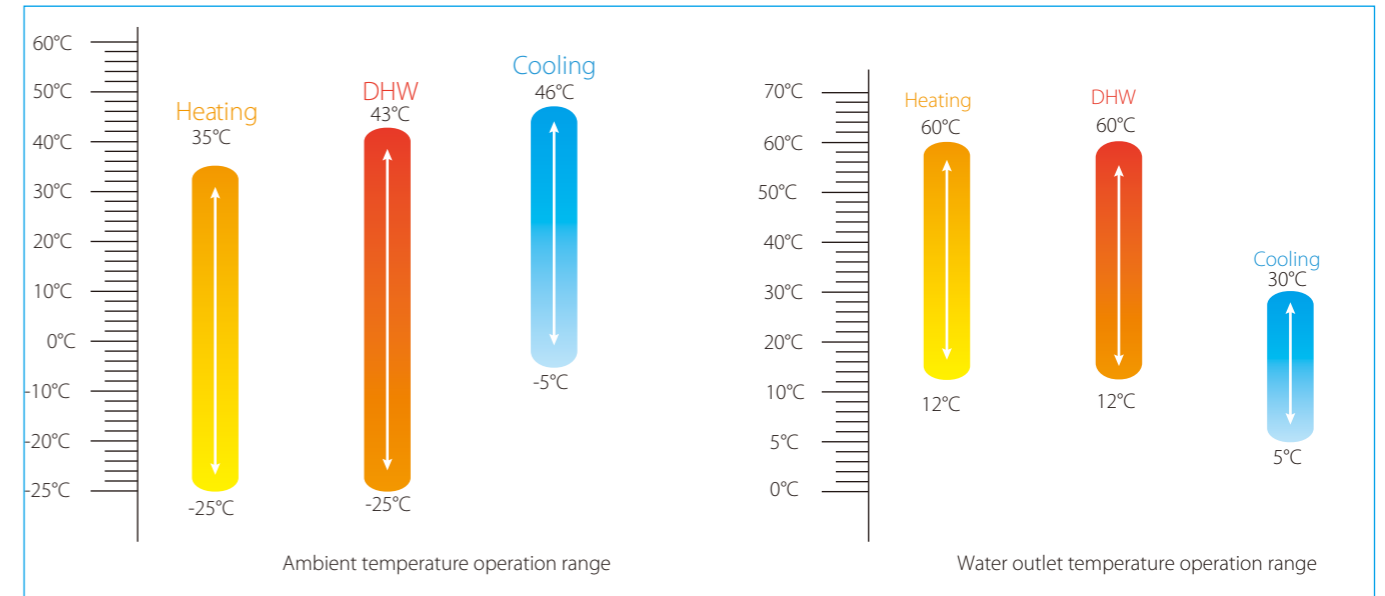

Easy installation and easy maintenance

- ❖ All hydronic components are located within the outdoor unit.
- ❖ Refrigerant system entirely contained within outdoor unit - no additional refrigerant piping required.
- ❖ Compact structure, easy for transportation and installation.
- ❖ Two-door design for easy access to internal components for easy maintenance.



Door 1: Access to hydronic components and electrical parts



Door 2: Access to refrigerant components and electrical parts.

- ❖ DC inverter technology to guarantee optimal operational reliability and efficiency.
- ❖ Spray liquid cooling control of compressor is benefit for enhancing heating capacity in low temperature condition.

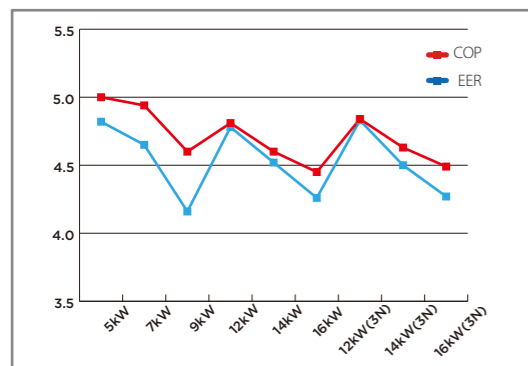

COP test conditions: ambient temp. 7°C; leaving water temp. 35°C
EER test conditions: ambient temp. 35°C; leaving water temp. 18°C

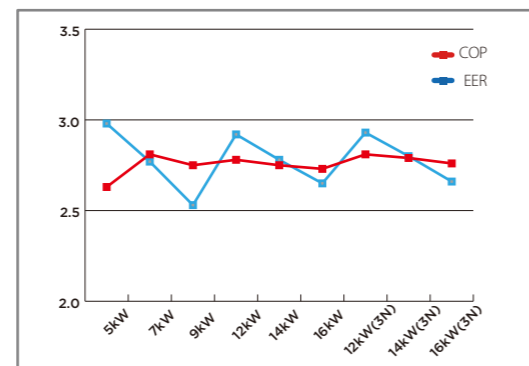

COP test conditions: ambient temp. 7°C; leaving water temp. 55°C
EER test conditions: ambient temp. 35°C; leaving water temp. 7°C

- ❖ Offers heating capacity of 100% at -7°C thanks to the large heat exchanger and large compressor.

Flexible operation and more comfort

❖ Weather dependent operation with climate correlation to ensure absolute comfort. Totally there are 32 climate correlation curves for choice. Once the curve is selected, the unit set the outlet water temperature automatically according to the outdoor ambient temperature.

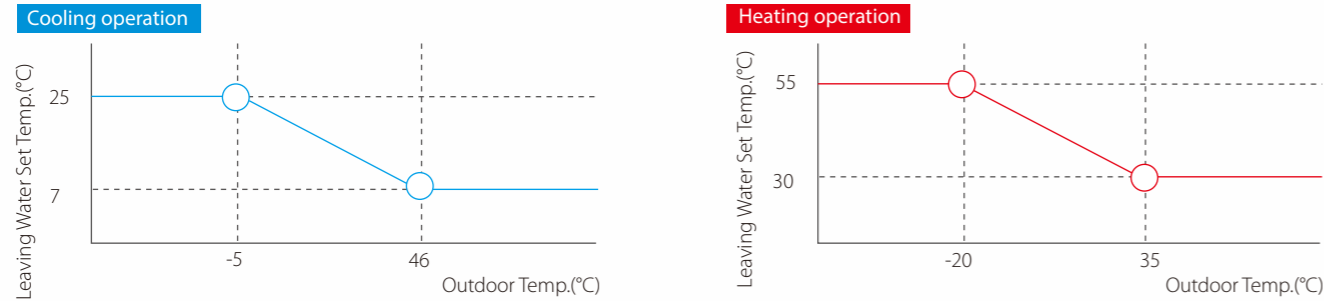

❖ Two zones control more flexibility
Temperature of each zone is separately controlled. Two zones control reduces water pump cycle time and save energy.

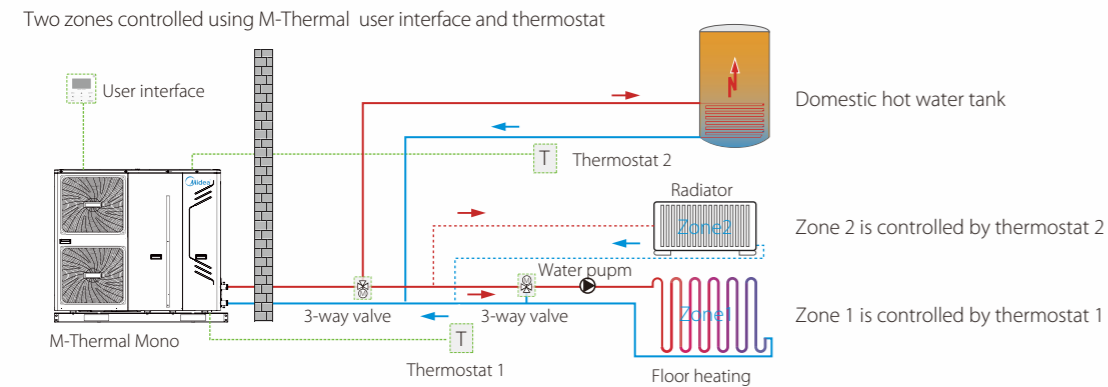
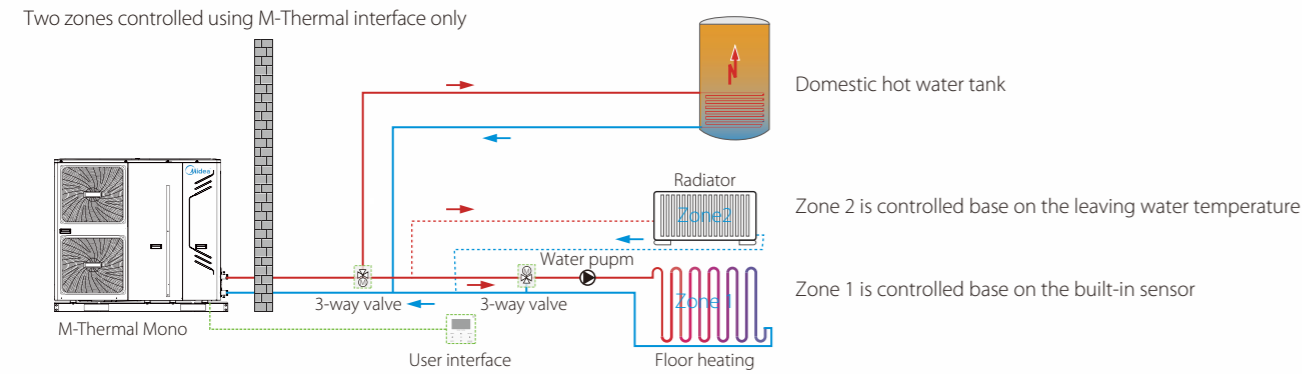

❖ Priority setting function and multi modes choice



Note:
1. Only when the immersion heater of tank is available can the disinfection mode be used.

❖ Special functions such as air purge, preheating for floor and floor drying up

User interface



- ❖ Newly designed touch-key wired controller.
- ❖ Check running parameters in real time
- ❖ Communication wire length customizable up to 150m.
- ❖ Built-in temperature sensor.
- ❖ Modbus protocol and network flexibility.

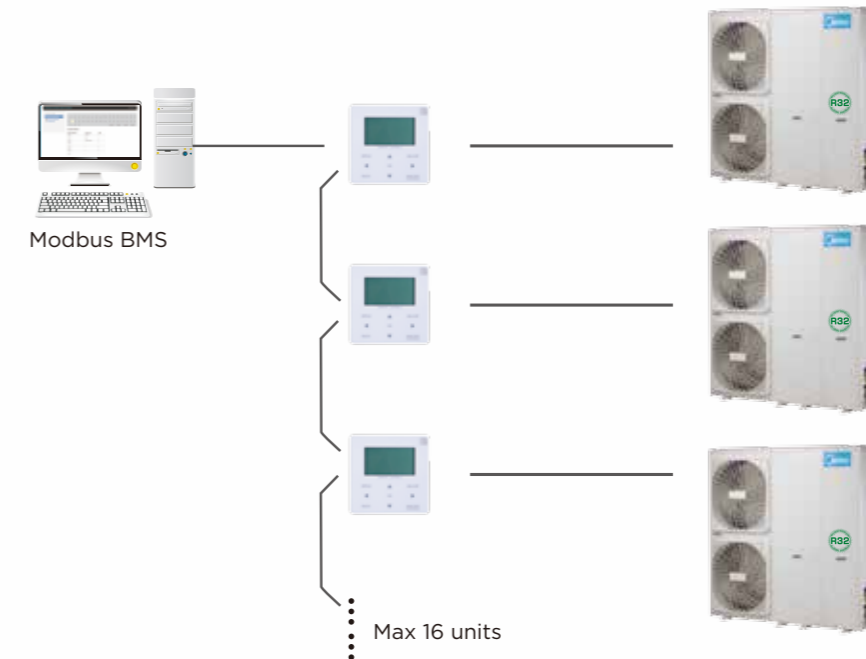

M-Thermal Split

High efficiency and total heat solution

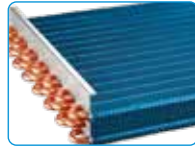

Fin-coil heat exchanger

Air side heat exchanger's inner-threaded copper pipes optimize heat exchange efficiency. Plate type hydrophilic aluminum foil used for air side heat exchange, which is easy for water drain and prevents forest to a great extent. Blue coating increases the resistance against corrosive agents, enhance durability.



Brushless DC fan motor

BLDC fan motor with stepless control helps to meet heating and cooling demands with low noise fan, super quiet operation, as well low power consumption.

DC inverter compressor

The newly designed twin rotary DC inverter compressor with permanent magnet brings low working sound, wide working frequency and precession control. The upgraded DC motor power system of inverter model forms a full DC frequency conversion system and dramatically reduces power consumption by more than 30%.

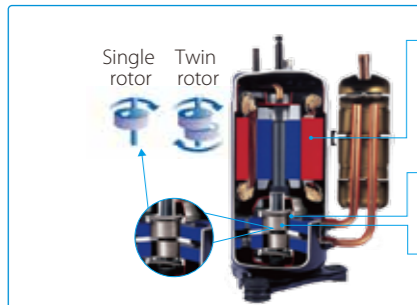

Compressor (Twin Rotary) structure

- High efficiency DC motor:**
 - Creative motor core design
 - High density neodymium magnet
 - Concentrated type stator
 - Wider operating frequency range
- Better balance and Extremely Low Vibration:**
 - Twin eccentric cams
 - 2 balance weights
- Highly Stable Moving Parts:**
 - Optimal material matching rollers and vanes
 - Optimize compressor drive technology
 - Highly robust bearings
 - Compact structure



- ❖ Twin rotary DC inverter compressor to guarantee optimal operational reliability and efficiency.
- ❖ Spray liquid cooling control of compressor is benefit for enhancing heating capacity in low temperature condition.



COP tested under: Ambient temp. 7°C/Outlet water temp. 35°C

EER tested under: Ambient temp. 35°C/Outlet water temp. 18°C



COP tested under: Ambient temp. 7°C/Outlet water temp. 55°C

EER tested under: Ambient temp. 35°C/Outlet water temp. 7°C

- ❖ Offers heating capacity of 100% at -7°C thanks to the large heat exchanger and large compressor.

- ❖ Backup electric heater is customizable for additional heating during extremely cold weather. The capacity of the backup electric heater is customizable and the output capacity is adjustable. The backup electric heater is installed in the hydronic box.
- ❖ Heating, cooling and domestic hot water: a total heat solution.
- ❖ Wide ambient temperature and water outlet temperature operating ranges.
- ❖ Compatible with additional heat sources (AHSs), including solar water heaters and boilers. AHSs can work together with heat pump or alternative for space heating and domestic hot water dependent on the system control.
- ❖ Wide ambient temperature and water outlet temperature operation ranges.

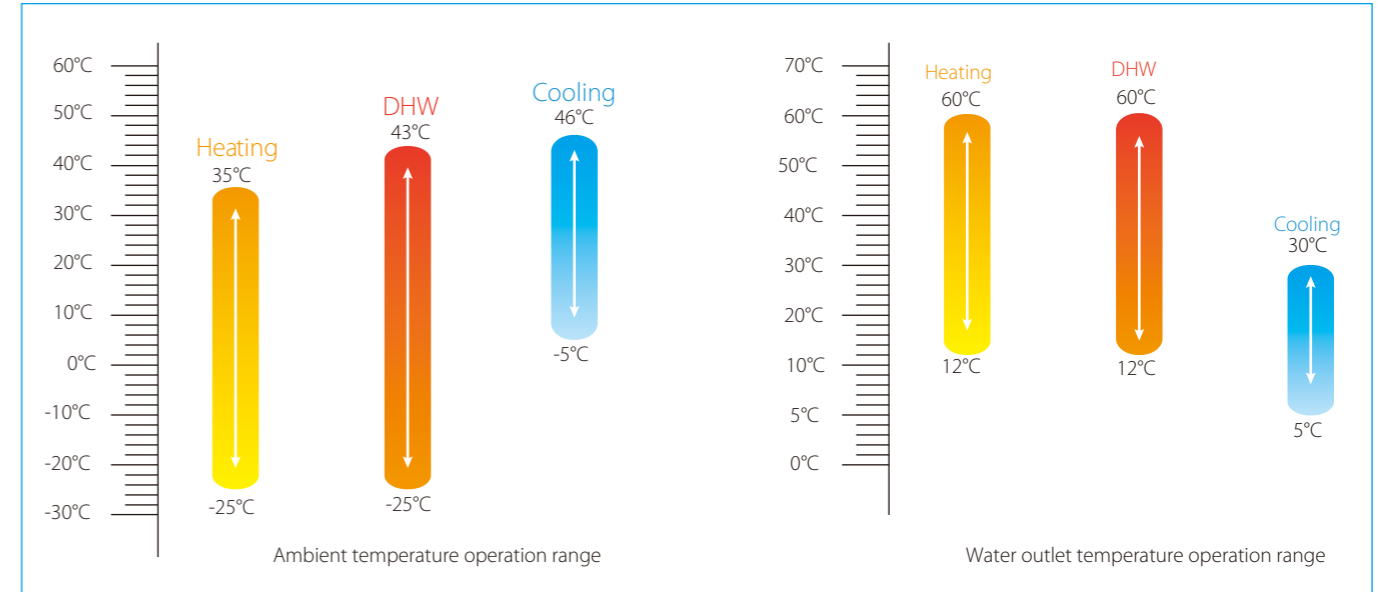

Flexible installation and easy maintenance

- ❖ Compact structure, independent hydronic box, flexible installation.
- ❖ Refrigerant pipes run indoors from the outdoor unit, no need extra insulation of water piping to protect from freezing up.
- ❖ Additional refrigerant charge only required if refrigerant piping length exceeds 15m.



Flexible operation and more comfort

- ❖ Weather dependent operation with climate correlation to ensure absolute comfort.
Totally there are 32 climate correlation curves for choice and custom curve is optional. Once the curve is selected, the unit set the outlet water temperature automatically according to the outdoor ambient temperature.

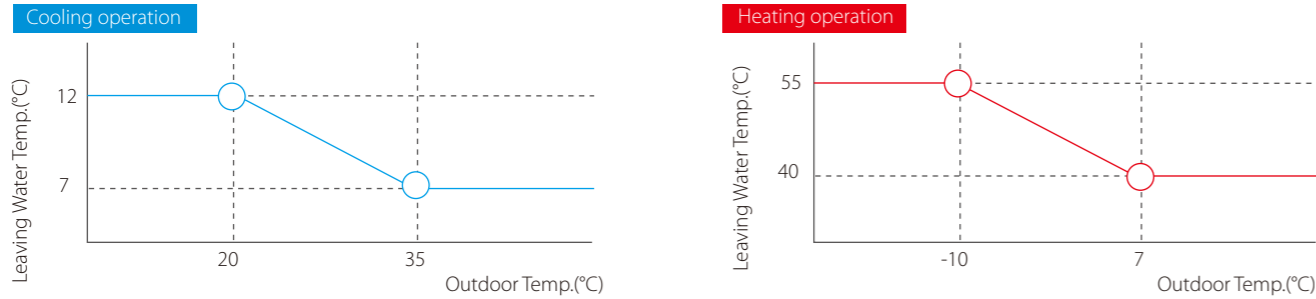

- ❖ Two zones controlled using M-Thermal interface only
Temperature of each zone is separately controlled. Two zones control reduces water pump cycle time and save energy.

Two zones controlled using M-Thermal one user interface

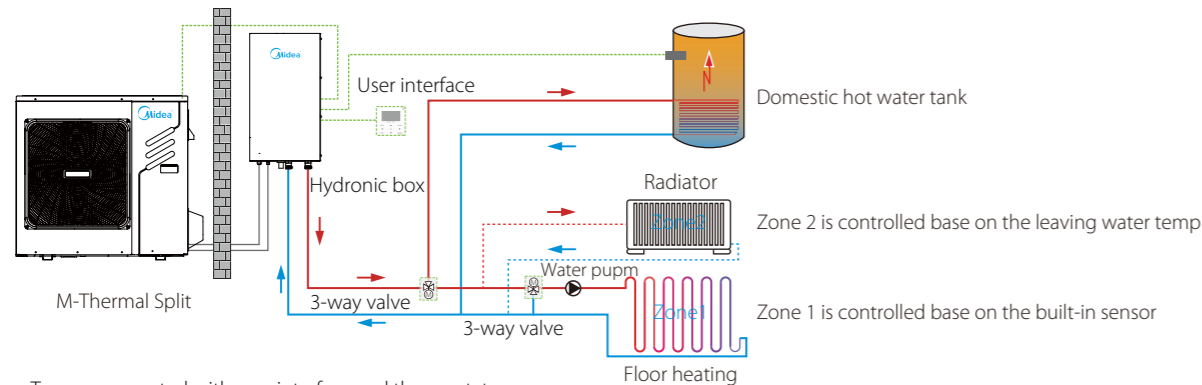

Two zones control with user interface and thermostat

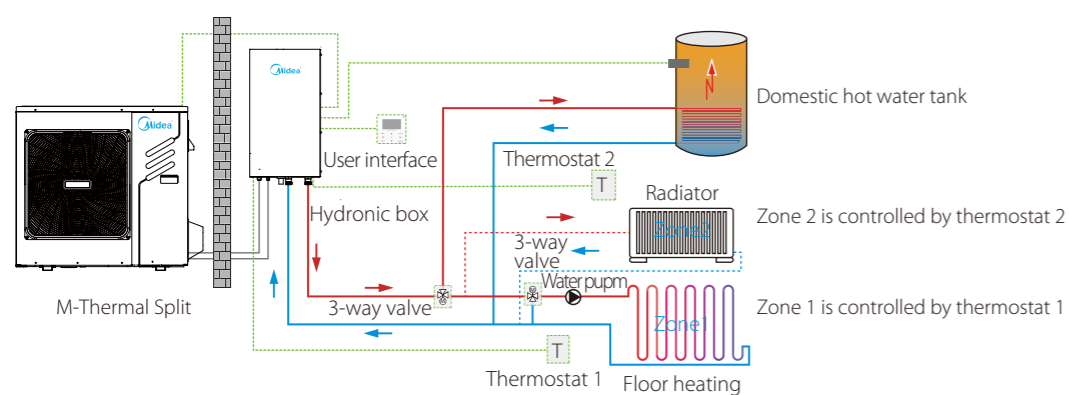

- ❖ Priority setting function and multi modes choice



- ❖ Special functions such as air purge, preheating for floor and floor drying up

Hydronic box

- ❖ Integrated water-side heat exchange solution for easy installation.

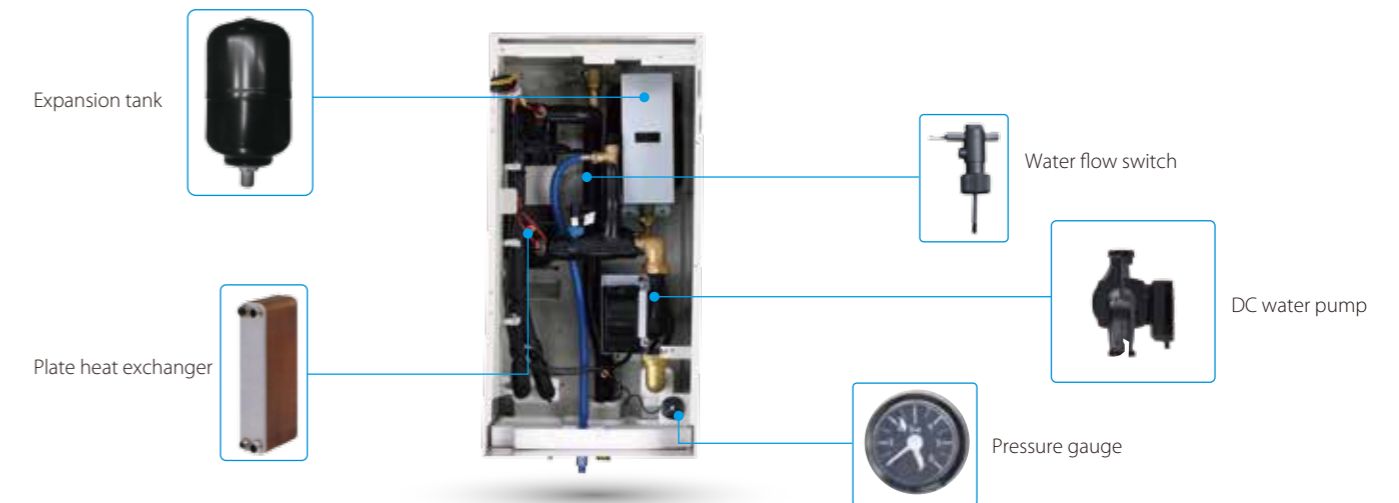

- ❖ Rotating electric control box enables easy maintenance access to all hydronic components.

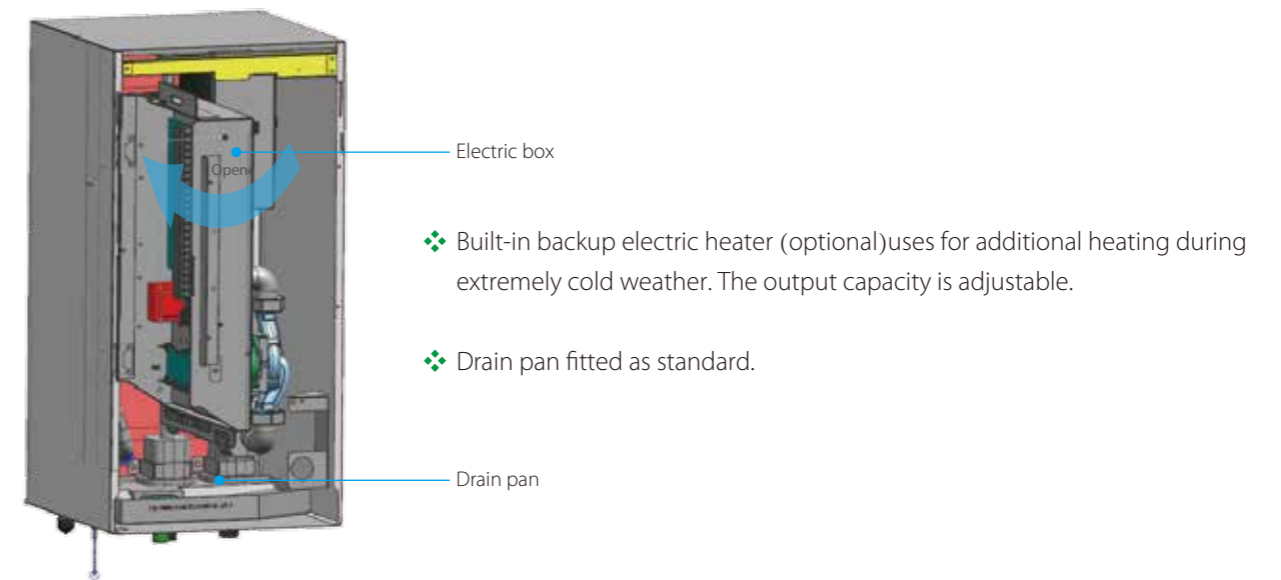

User interface



- ❖ Newly designed touch-key wired controller.
- ❖ Check running parameters in real time
- ❖ Communication wire length customizable up to 150m.
- ❖ Built-in temperature sensor.

User interface

- ❖ Modbus protocol and network flexibility.

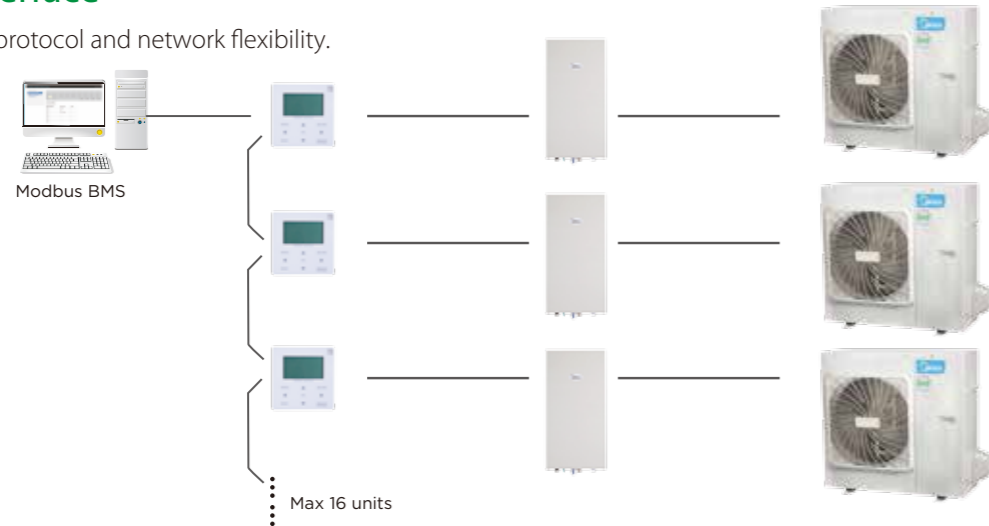

Smart Grid function

Unit adjusts the operation according to different electrical signals to realize energy saving.

- ❖ Renewable electric energy signal: solar energy is converted into electric energy for unit to produce domestic hot water.
- ❖ Common electric energy signal: unit operates according to users' need.
- ❖ Expensive electric energy signal: only available for cooling or heating mode and user can set the maximum operating time.



APP control

- ❖ Remote control
- ❖ Check the running state of equipment, zone switch, operation mode and temperature.
- ❖ Set switch, operation mode and temperature of each zone
- ❖ Display fault information



Typical Applications

System configurations

M-Thermal system can be configured to run with the electric heater either enabled or disabled and can also be used in conjunction with an auxiliary heat source such as a boiler.

The chosen configuration affects the size of heat pump that is required. Three typical configurations are described below.

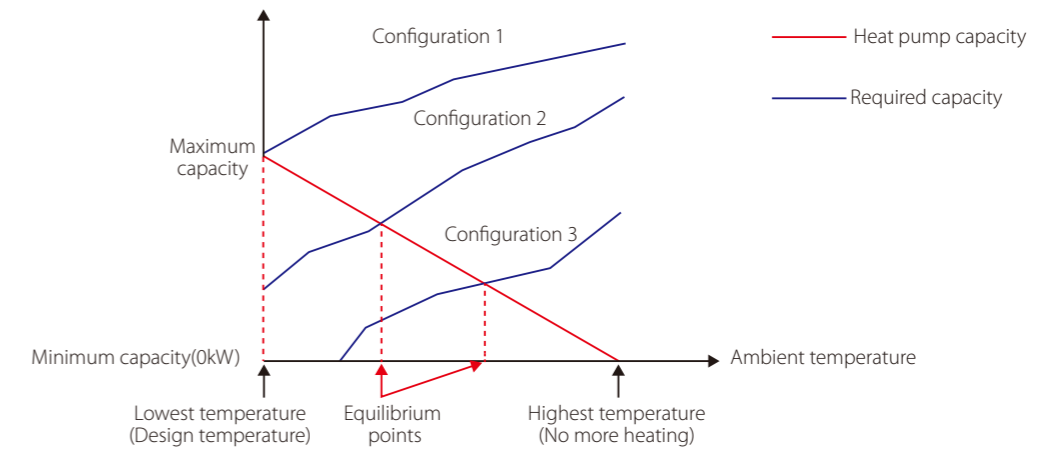

Configuration 1: Heat pump only

- ❖ The heat pump covers the required capacity and no extra heating capacity is necessary.
- ❖ Requires selection of larger capacity heat pump and implies higher initial investment.
- ❖ Ideal for new construction in projects where energy efficiency is paramount.

Configuration 2: Heat pump and backup electric heater

- ❖ Heat pump covers the required capacity until the ambient temperature drops below the point at which the heat pump is able to provide sufficient capacity. When the ambient temperature is below this equilibrium point, the backup electric heater supplies the required additional heating capacity.
- ❖ Best balance between initial investment and running costs, results in lowest lifecycle cost.
- ❖ Ideal for new construction.

Configuration 3: Heat pump with auxiliary heat source

- ❖ Heat pump covers the required capacity until the ambient temperature drops below the point at which the heat pump is able to provide sufficient capacity. When the ambient temperature is below this equilibrium point, depending on the system settings, either the auxiliary heat source supplies the required additional heating capacity or the heat pump does not run and the auxiliary heat source covers the required capacity.
- ❖ Enables selection of lower capacity heat pump.
- ❖ Ideal for refurbishments and upgrades.

Selection Procedure

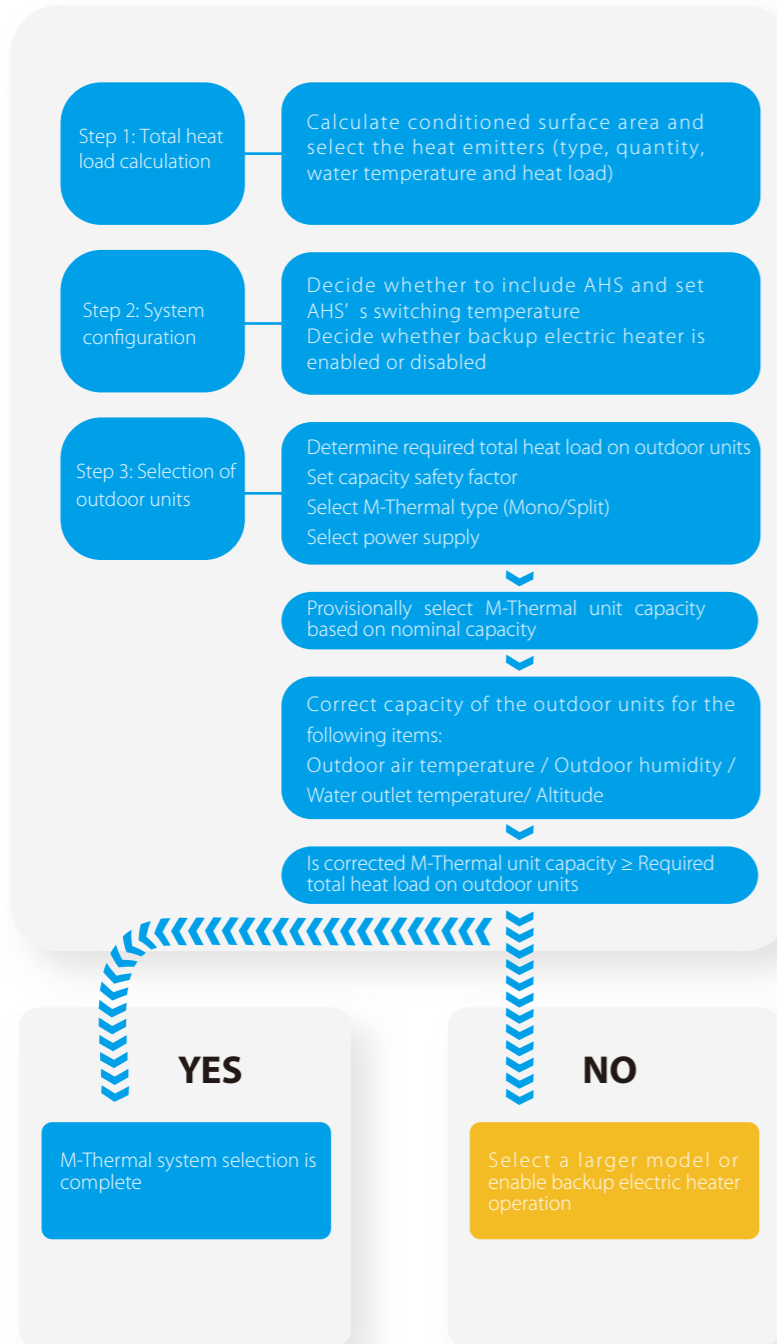

Leaving Water Temperature (LWT)

The recommended design LTW ranges for different types of heat emitter are:

- ❖ For floor heating: 30°C to 35°C
- ❖ For fan coil units: 30°C to 45°C
- ❖ For low temperature radiators: 40°C to 50°C

M-Thermal Mono

❖ Application 1: Space Heating Only

The room thermostat is used as a switch. When there is a heating request from the room thermostat, the Mono unit operates to achieve the target water temperature set on the user interface. When the room temperature reaches the thermostat's set temperature, the unit stops.

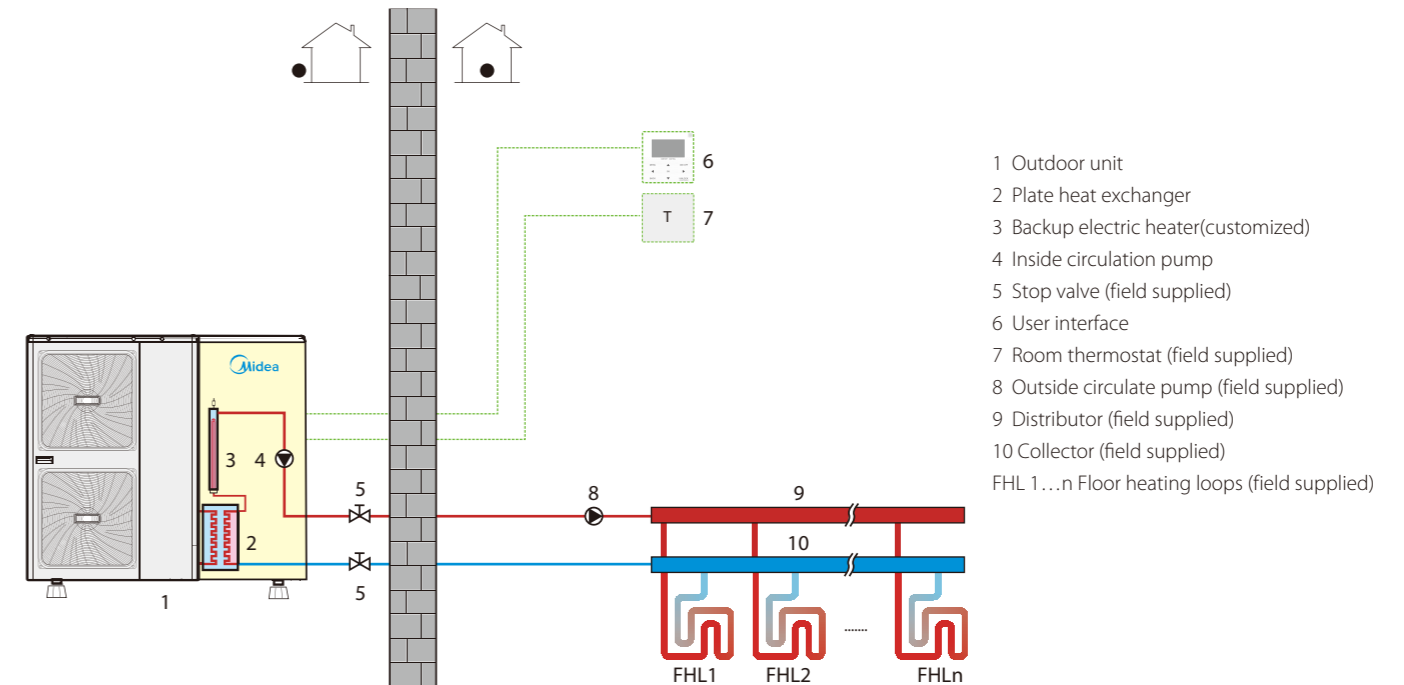

❖ Application 2: Space Heating and Domestic Hot Water

The room thermostats are not connected to the Mono unit but to a motorized valve. Each room' s temperature is regulated by the motorized valve on its water circuit. Domestic hot water is supplied from the domestic hot water tank connected to the Mono unit. A bypass valve is required.

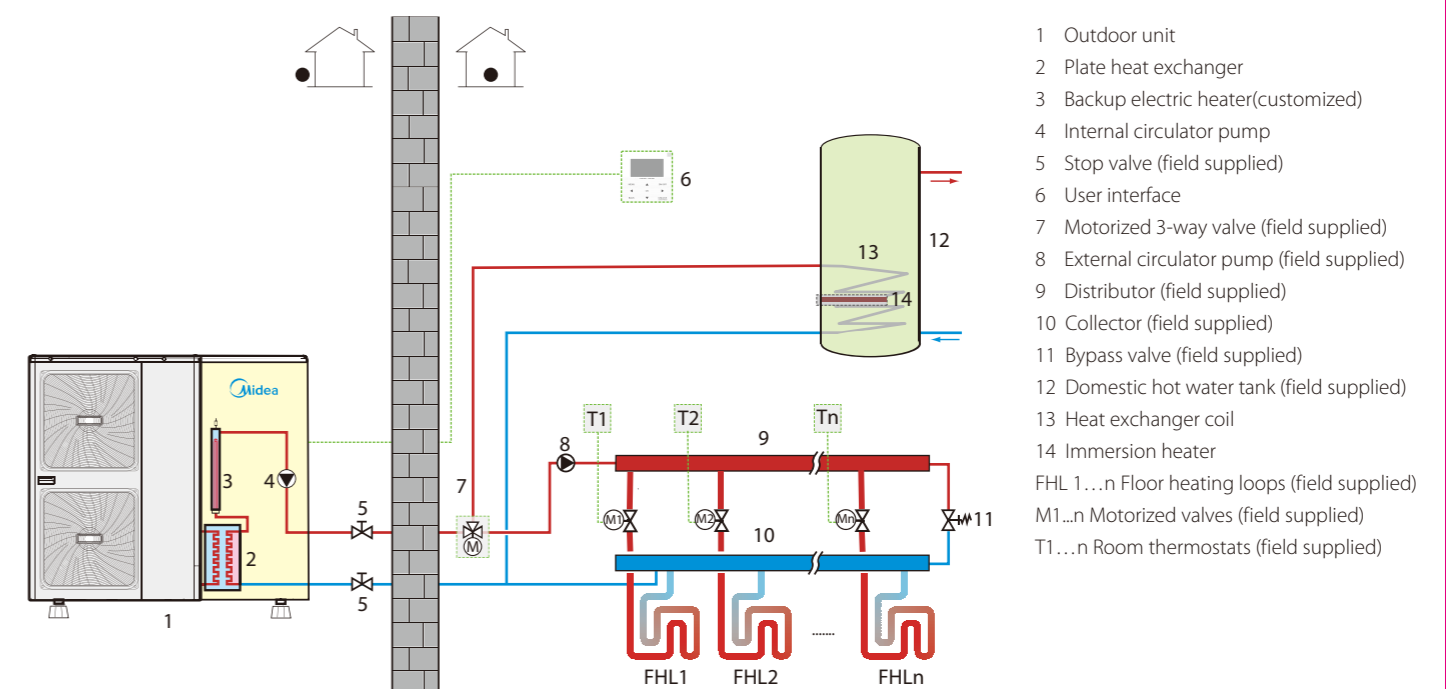

❖ **Application 3: Space Heating, Space Cooling and Domestic Hot Water**

Floor heating loops and fan coil units are used for space heating and fan coil units are used for space cooling. Domestic hot water is supplied from the domestic hot water tank connected to the Mono unit. The unit switches to heating or cooling mode according to the temperature detected by the room thermostat. In space cooling mode, the 2-way valve is closed to prevent cold water entering the floor heating loops.

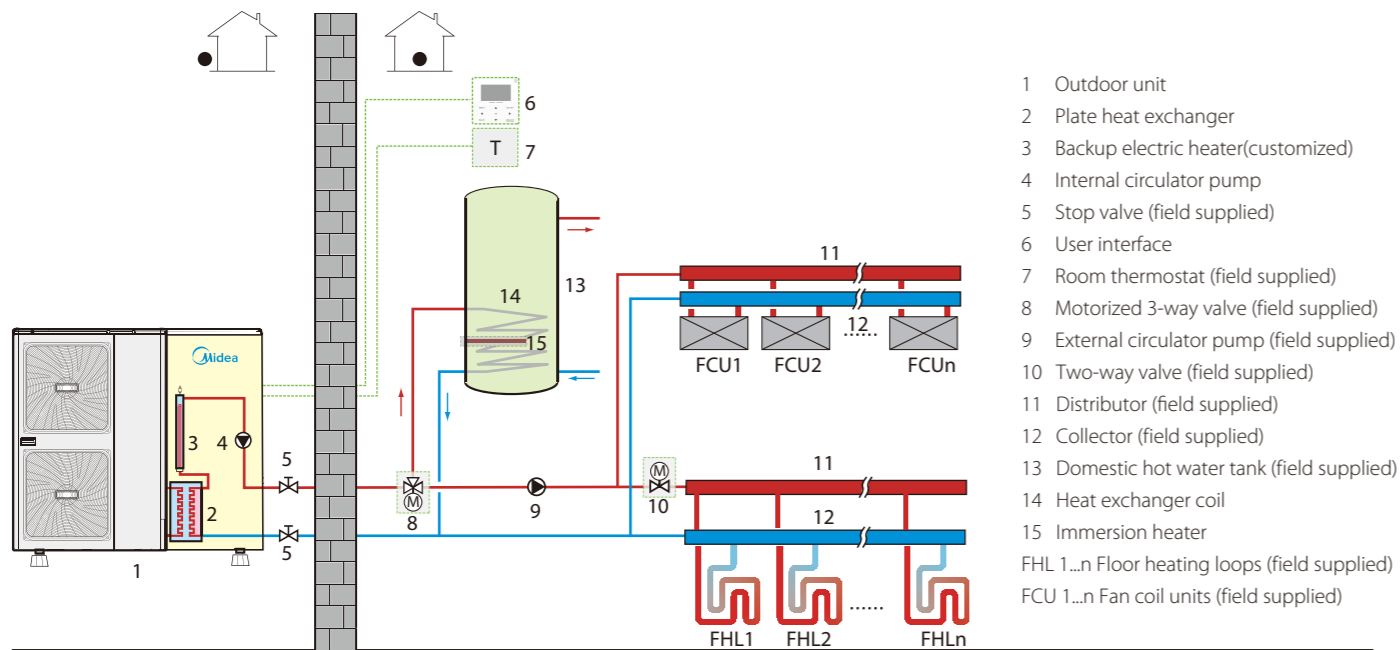

❖ **Application 5: Space Heating and Domestic Hot Water (Bivalent)**

5-1 Auxiliary heat source provides space heating only

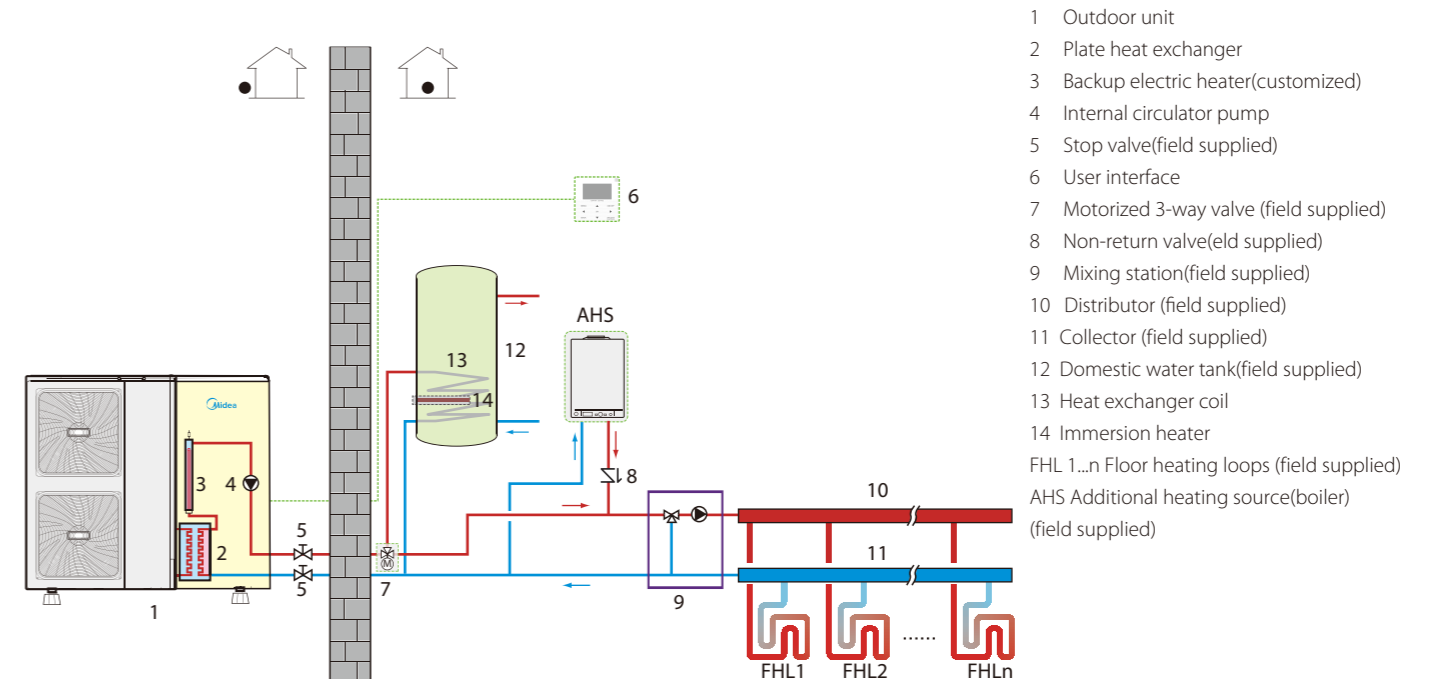

❖ **Application 4: Space Heating and Space Cooling**

Floor heating loops and fan coil units are used for space heating and fan coil units are used for space cooling. The room thermostats are not connected to the Mono unit but are connected to the fan coil units

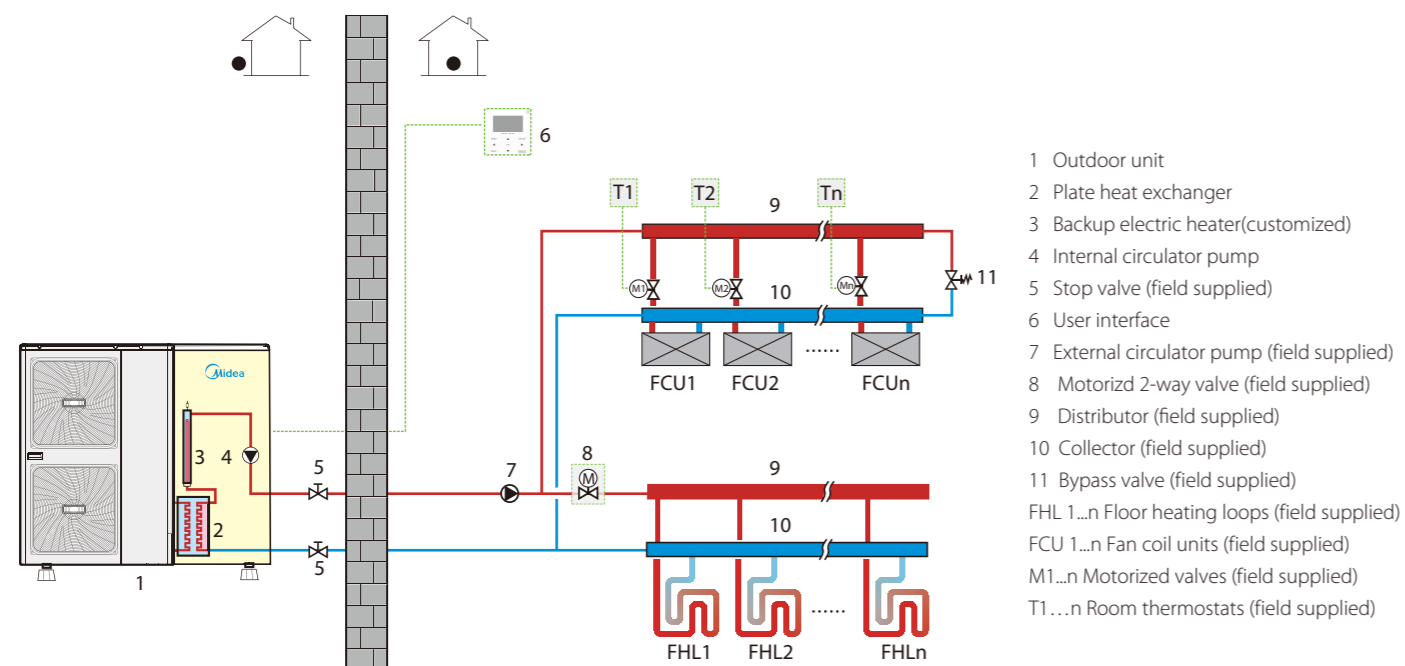

5-2 Auxiliary heat source provides space heating and domestic hot water

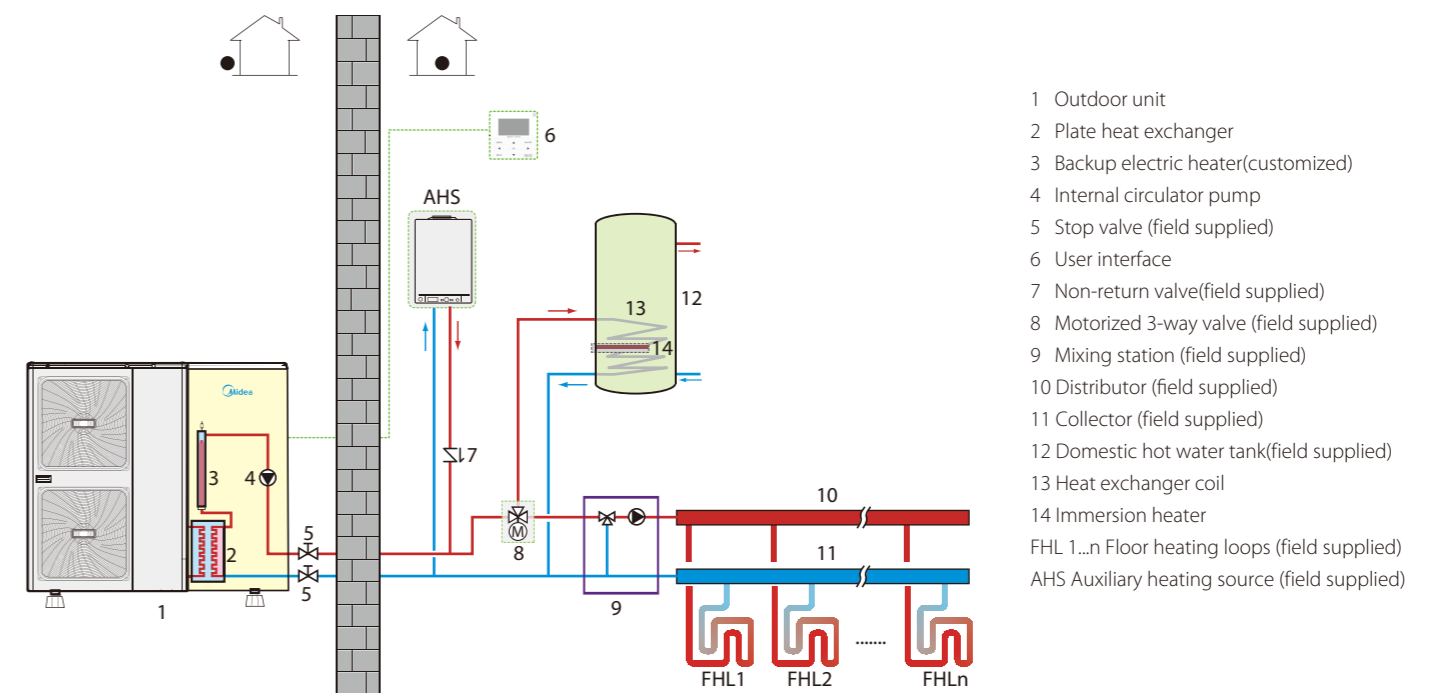

5-3 Auxiliary heat source provides additional heating

If the Mono unit's outlet temperature is too low, the auxiliary heat source provides additional heating to raise the water temperature to the set temperature. An additional 3-way valve is required. When the Mono unit's outlet temperature is too low, the 3-way valve is open and the water flows through the auxiliary heat source. When the Mono unit's outlet temperature is high enough, the 3-way valve is closed.

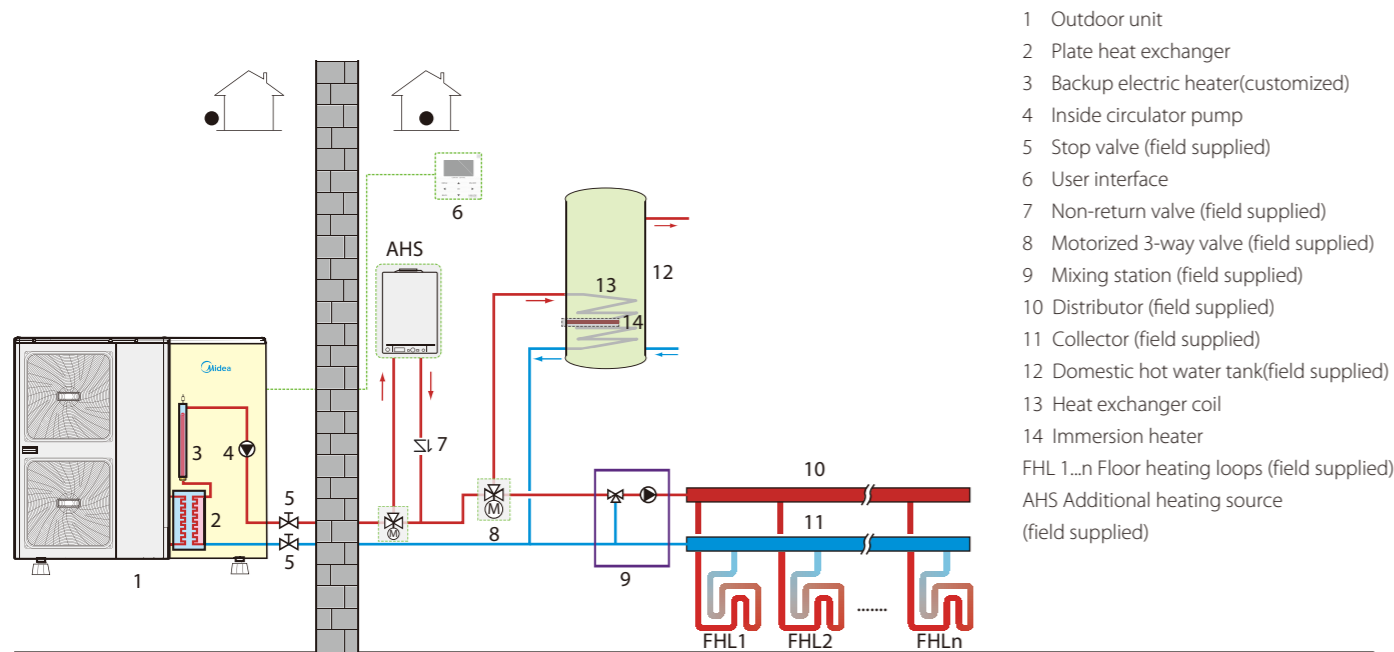

- 1 Outdoor unit
- 2 Plate heat exchanger
- 3 Backup electric heater(customized)
- 4 Inside circulator pump
- 5 Stop valve (field supplied)
- 6 User interface
- 7 Non-return valve (field supplied)
- 8 Motorized 3-way valve (field supplied)
- 9 Mixing station (field supplied)
- 10 Distributor (field supplied)
- 11 Collector (field supplied)
- 12 Domestic hot water tank(field supplied)
- 13 Heat exchanger coil
- 14 Immersion heater
- FHL 1...n Floor heating loops (field supplied)
- AHS Additional heating source (field supplied)

❖ Application 6: Space Heating Through Floor Heating Loops and Fan Coil Units

Dual setpoint function application with or without two room thermostat connect to the outdoor unit. The floor heating loops and fan coil units require different operating water temperatures. To achieve these two set points, a mixing station is required. Room thermostats for each zone are optional.

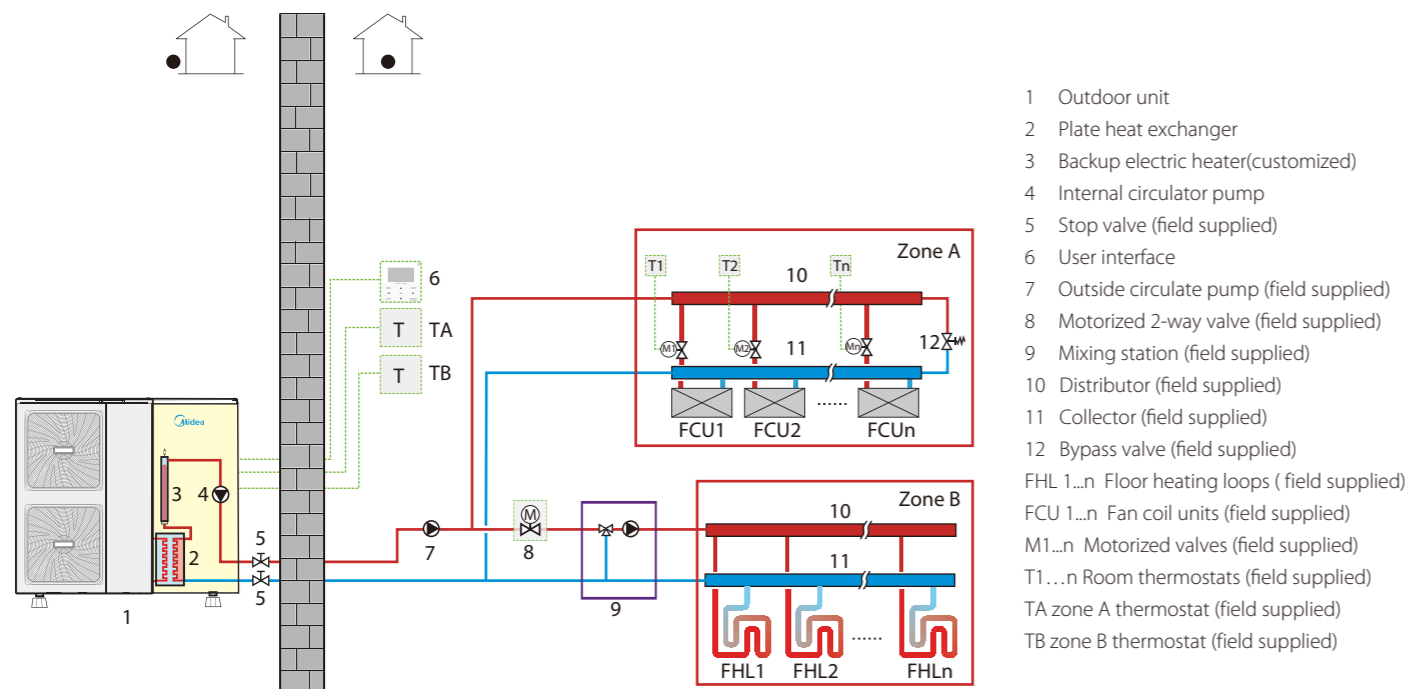

- 1 Outdoor unit
- 2 Plate heat exchanger
- 3 Backup electric heater(customized)
- 4 Internal circulator pump
- 5 Stop valve (field supplied)
- 6 User interface
- 7 Outside circulate pump (field supplied)
- 8 Motorized 2-way valve (field supplied)
- 9 Mixing station (field supplied)
- 10 Distributor (field supplied)
- 11 Collector (field supplied)
- 12 Bypass valve (field supplied)
- FHL 1...n Floor heating loops (field supplied)
- FCU 1...n Fan coil units (field supplied)
- M1...n Motorized valves (field supplied)
- T1...n Room thermostats (field supplied)
- TA zone A thermostat (field supplied)
- TB zone B thermostat (field supplied)

❖ Application 7: Space Heating and Domestic Hot Water Heating with a solar energy kit

Space heating application and domestic hot water heating with a solar energy kit connected to the system; space heating is provided by heat pump, domestic hot water heating is provided by heat pump and solar energy kit.

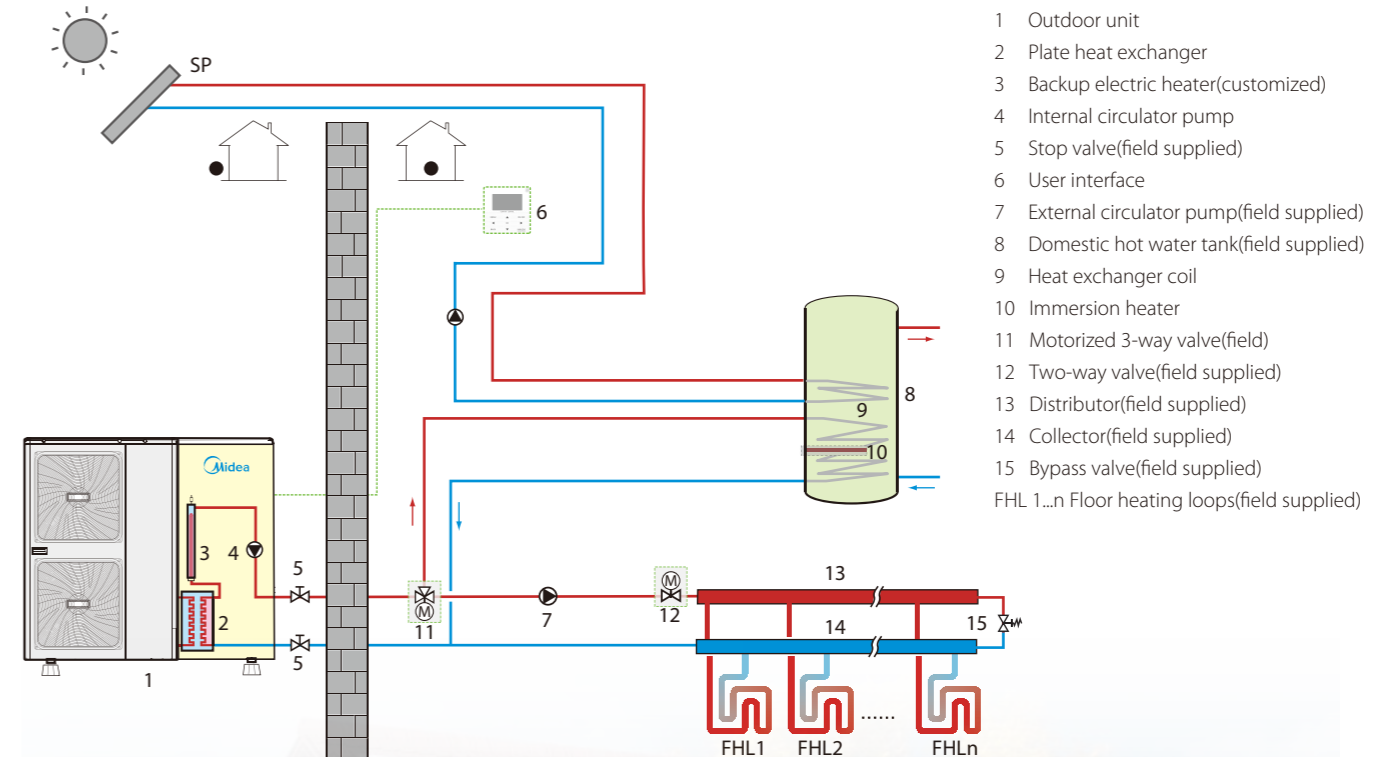

- 1 Outdoor unit
- 2 Plate heat exchanger
- 3 Backup electric heater(customized)
- 4 Internal circulator pump
- 5 Stop valve(field supplied)
- 6 User interface
- 7 External circulator pump(field supplied)
- 8 Domestic hot water tank(field supplied)
- 9 Heat exchanger coil
- 10 Immersion heater
- 11 Motorized 3-way valve(field supplied)
- 12 Two-way valve(field supplied)
- 13 Distributor(field supplied)
- 14 Collector(field supplied)
- 15 Bypass valve(field supplied)
- FHL 1...n Floor heating loops(field supplied)



M-Thermal Split

❖ Application 1: Space Heating Only

The room thermostat is used as a switch. When there is a heating request from the room thermostat, the unit operates to achieve the target water temperature set on the user interface. When the room temperature reaches the thermostat's set temperature, the unit stops.

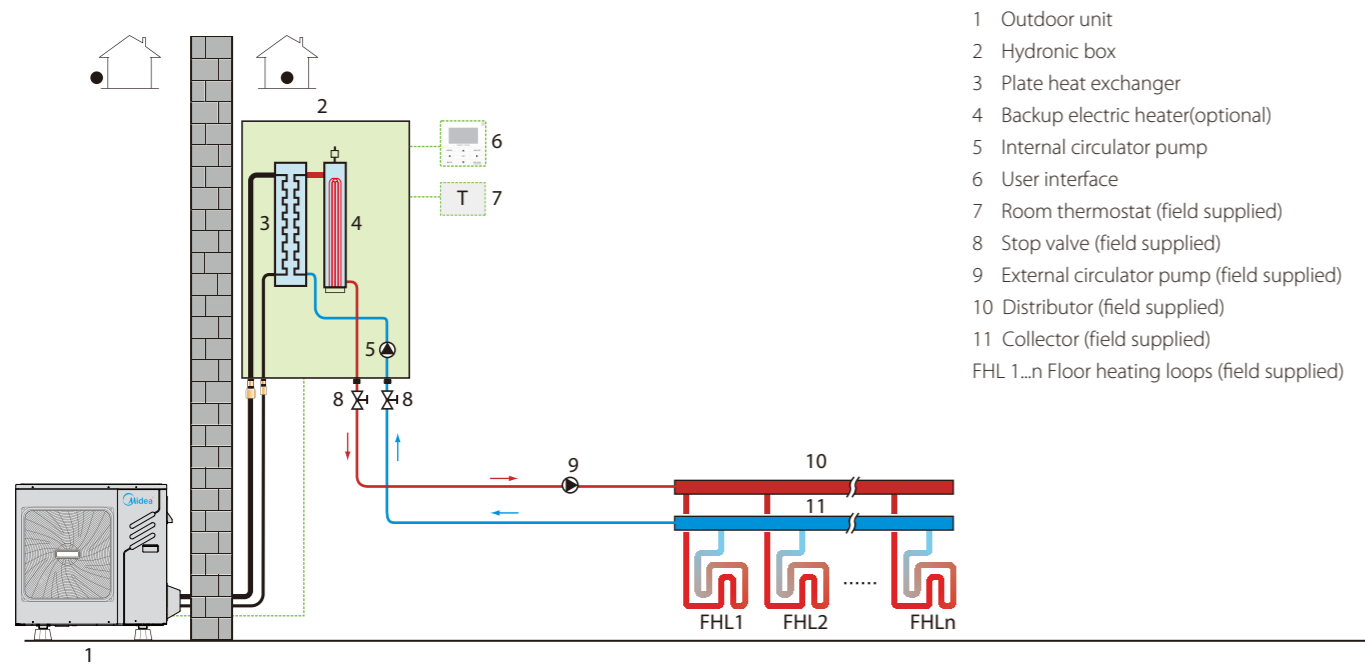

- 1 Outdoor unit
- 2 Hydronic box
- 3 Plate heat exchanger
- 4 Backup electric heater(optional)
- 5 Internal circulator pump
- 6 User interface
- 7 Room thermostat (field supplied)
- 8 Stop valve (field supplied)
- 9 External circulator pump (field supplied)
- 10 Distributor (field supplied)
- 11 Collector (field supplied)
- FHL 1...n Floor heating loops (field supplied)

❖ Application 2: Space Heating and Domestic Hot Water

The room thermostats are not connected to the hydronic box but to a motorized valve. Each room's temperature is regulated by the motorized valve on its water circuit. Domestic hot water is supplied from the domestic hot water tank connected to the hydronic box. A bypass valve is required.

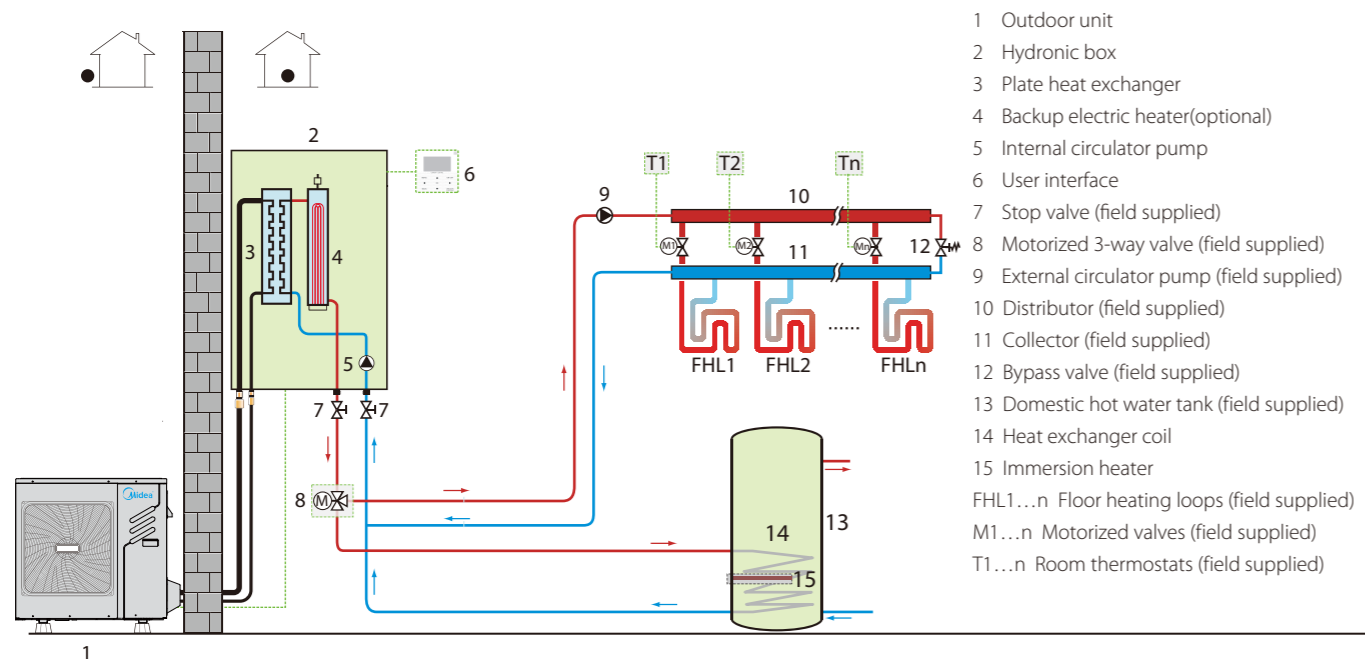

- 1 Outdoor unit
- 2 Hydronic box
- 3 Plate heat exchanger
- 4 Backup electric heater(optional)
- 5 Internal circulator pump
- 6 User interface
- 7 Stop valve (field supplied)
- 8 Motorized 3-way valve (field supplied)
- 9 External circulator pump (field supplied)
- 10 Distributor (field supplied)
- 11 Collector (field supplied)
- 12 Bypass valve (field supplied)
- 13 Domestic hot water tank (field supplied)
- 14 Heat exchanger coil
- 15 Immersion heater
- FHL1...n Floor heating loops (field supplied)
- M1...n Motorized valves (field supplied)
- T1...n Room thermostats (field supplied)

❖ Application 3: Space Heating, Space Cooling and Domestic Hot Water

Floor heating loops and fan coil units are used for space heating and fan coil units are used for space cooling. Domestic hot water is supplied from the domestic hot water tank connected to the hydronic box. The unit switches to heating or cooling mode according to the temperature detected by the room thermostat. In space cooling mode, the 2-way valve is closed to prevent cold water entering the floor heating loops.

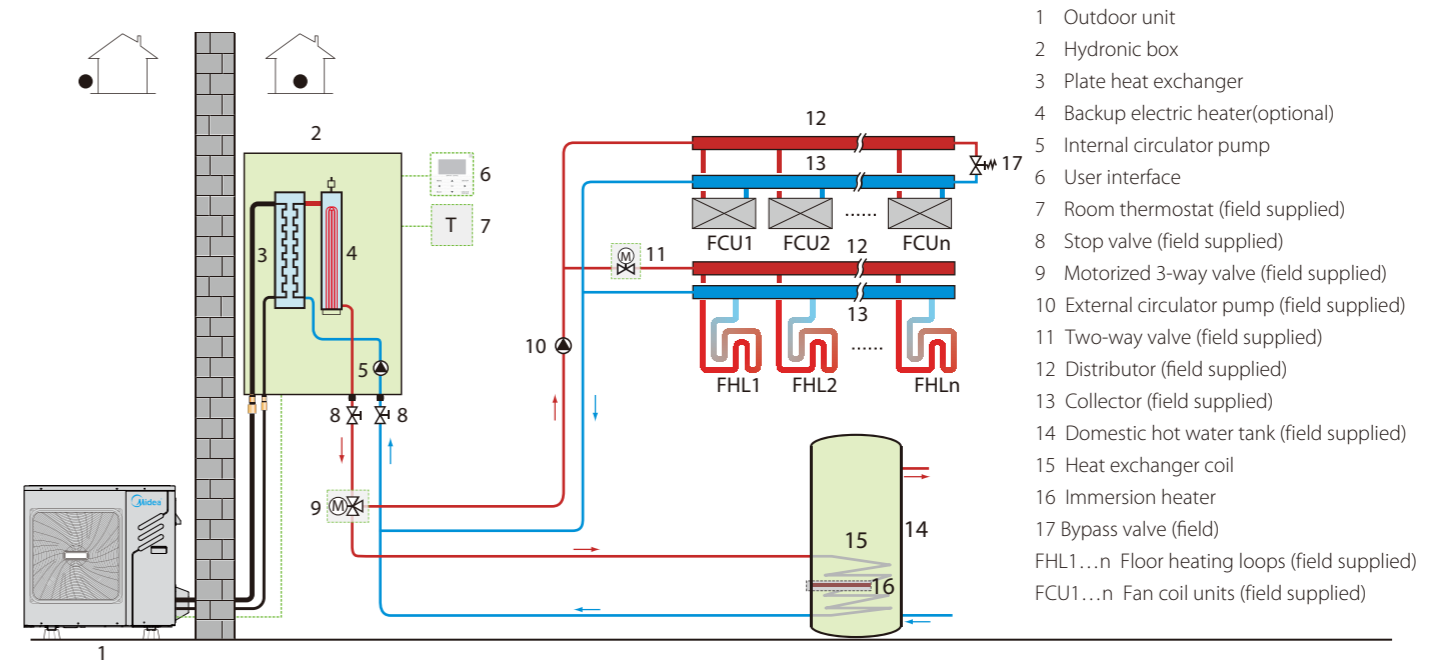

- 1 Outdoor unit
- 2 Hydronic box
- 3 Plate heat exchanger
- 4 Backup electric heater(optional)
- 5 Internal circulator pump
- 6 User interface
- 7 Room thermostat (field supplied)
- 8 Stop valve (field supplied)
- 9 Motorized 3-way valve (field supplied)
- 10 External circulator pump (field supplied)
- 11 Two-way valve (field supplied)
- 12 Distributor (field supplied)
- 13 Collector (field supplied)
- 14 Domestic hot water tank (field supplied)
- 15 Heat exchanger coil
- 16 Immersion heater
- 17 Bypass valve (field)
- FHL1...n Floor heating loops (field supplied)
- FCU1...n Fan coil units (field supplied)

❖ Application 4: Space Heating and Space Cooling

Floor heating loops and fan coil units are used for space heating and fan coil units are used for space cooling. The room thermostats are not connected to the hydronic box but are connected to the fan coil units.

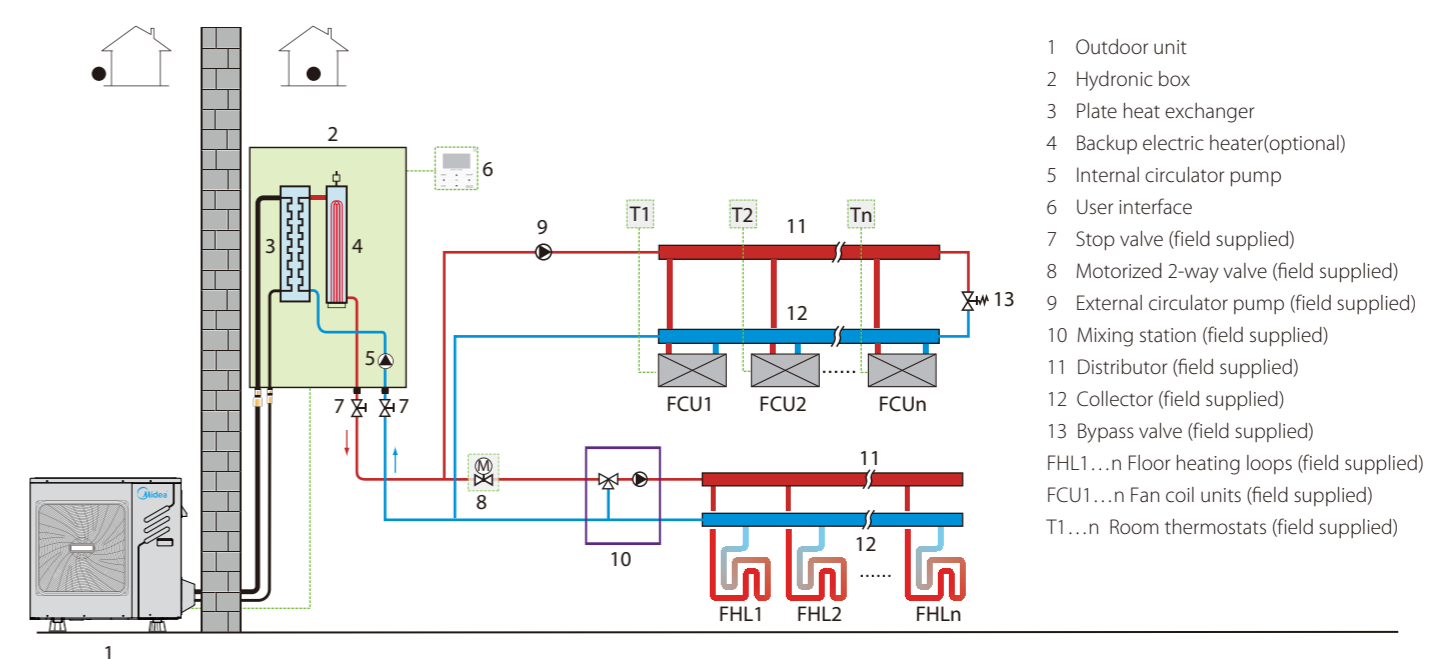

- 1 Outdoor unit
- 2 Hydronic box
- 3 Plate heat exchanger
- 4 Backup electric heater(optional)
- 5 Internal circulator pump
- 6 User interface
- 7 Stop valve (field supplied)
- 8 Motorized 2-way valve (field supplied)
- 9 External circulator pump (field supplied)
- 10 Mixing station (field supplied)
- 11 Distributor (field supplied)
- 12 Collector (field supplied)
- 13 Bypass valve (field supplied)
- FHL1...n Floor heating loops (field supplied)
- FCU1...n Fan coil units (field supplied)
- T1...n Room thermostats (field supplied)

❖ **Application 5: Space Heating and Domestic Hot Water (Bivalent)**

5-1 Auxiliary heat source provides space heating only

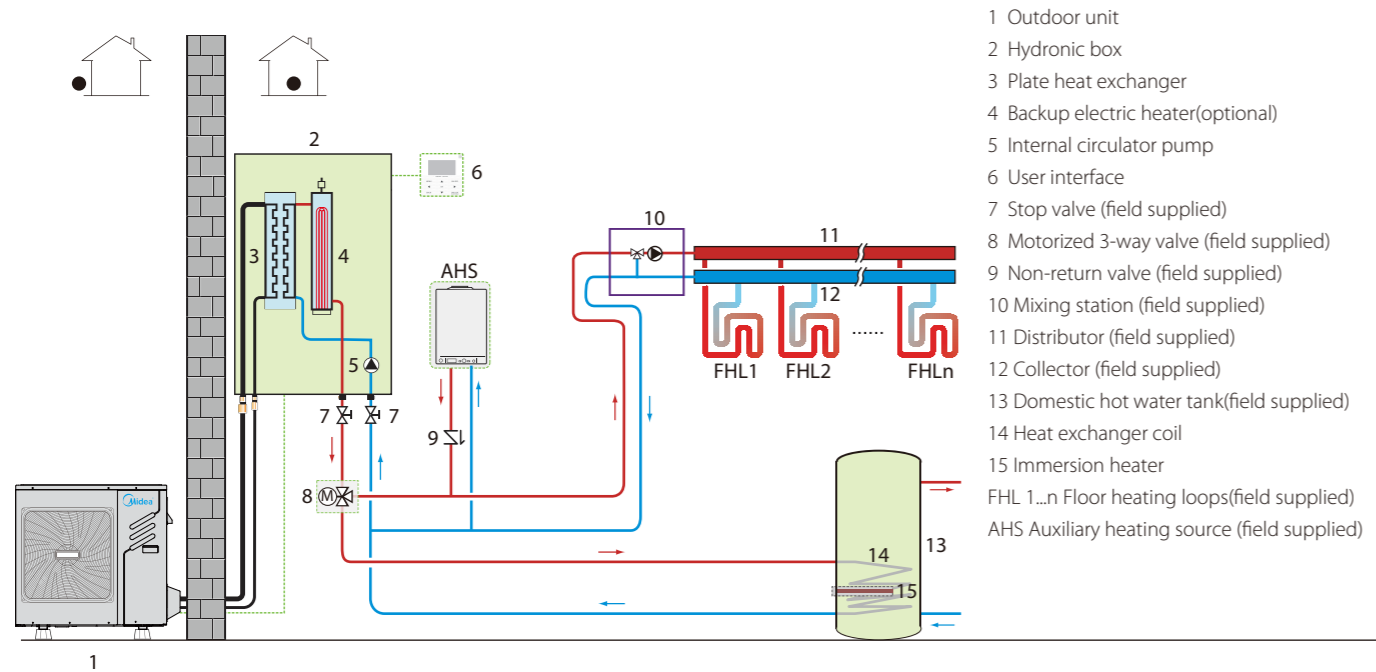

- 1 Outdoor unit
- 2 Hydronic box
- 3 Plate heat exchanger
- 4 Backup electric heater(optional)
- 5 Internal circulator pump
- 6 User interface
- 7 Stop valve (field supplied)
- 8 Motorized 3-way valve (field supplied)
- 9 Non-return valve (field supplied)
- 10 Mixing station (field supplied)
- 11 Distributor (field supplied)
- 12 Collector (field supplied)
- 13 Domestic hot water tank(field supplied)
- 14 Heat exchanger coil
- 15 Immersion heater
- FHL 1...n Floor heating loops(field supplied)
- AHS Auxiliary heating source (field supplied)

5-3 Auxiliary heat source provides additional heating

If the unit's outlet temperature is too low, the auxiliary heat source provides additional heating to raise the water temperature to the set temperature. An additional 3-way valve is required. When the unit's outlet temperature is too low, the 3-way valve is open and the water flows through the auxiliary heat source. When the unit's outlet temperature is high enough, the 3-way valve is closed.

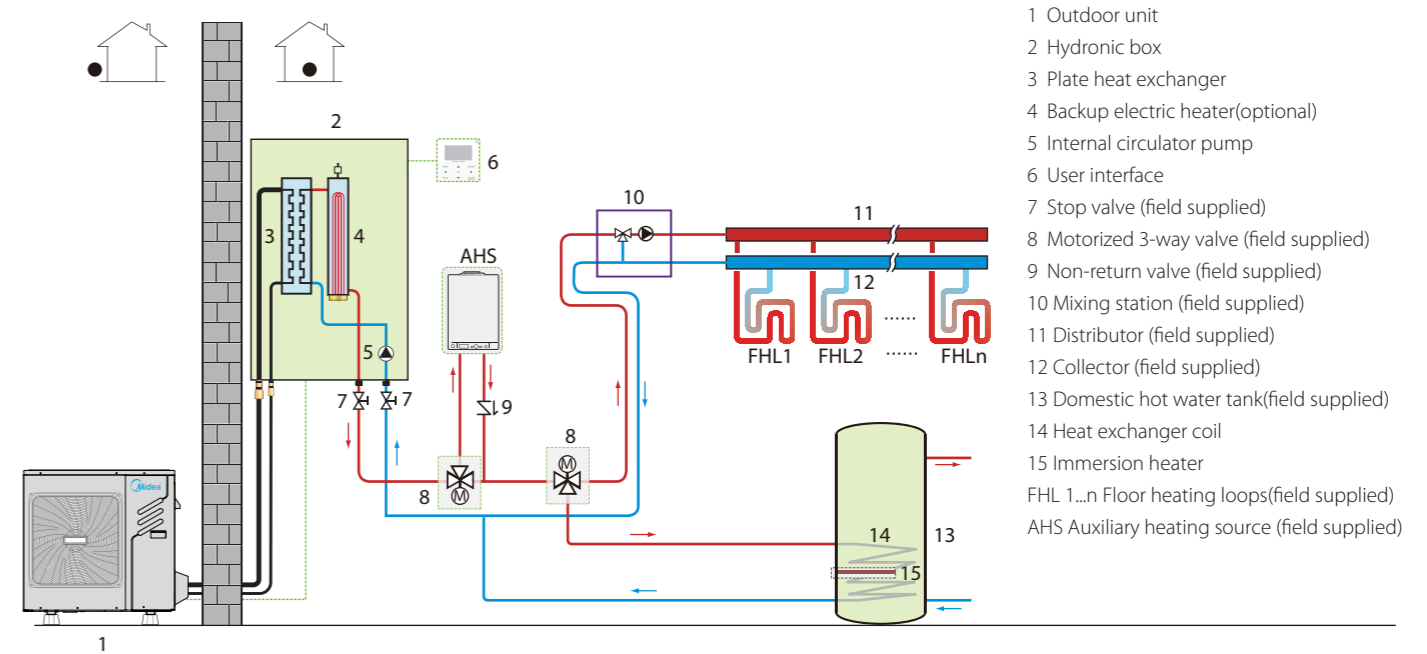

- 1 Outdoor unit
- 2 Hydronic box
- 3 Plate heat exchanger
- 4 Backup electric heater(optional)
- 5 Internal circulator pump
- 6 User interface
- 7 Stop valve (field supplied)
- 8 Motorized 3-way valve (field supplied)
- 9 Non-return valve (field supplied)
- 10 Mixing station (field supplied)
- 11 Distributor (field supplied)
- 12 Collector (field supplied)
- 13 Domestic hot water tank(field supplied)
- 14 Heat exchanger coil
- 15 Immersion heater
- FHL 1...n Floor heating loops(field supplied)
- AHS Auxiliary heating source (field supplied)

5-2 Auxiliary heat source provides space heating and domestic hot water

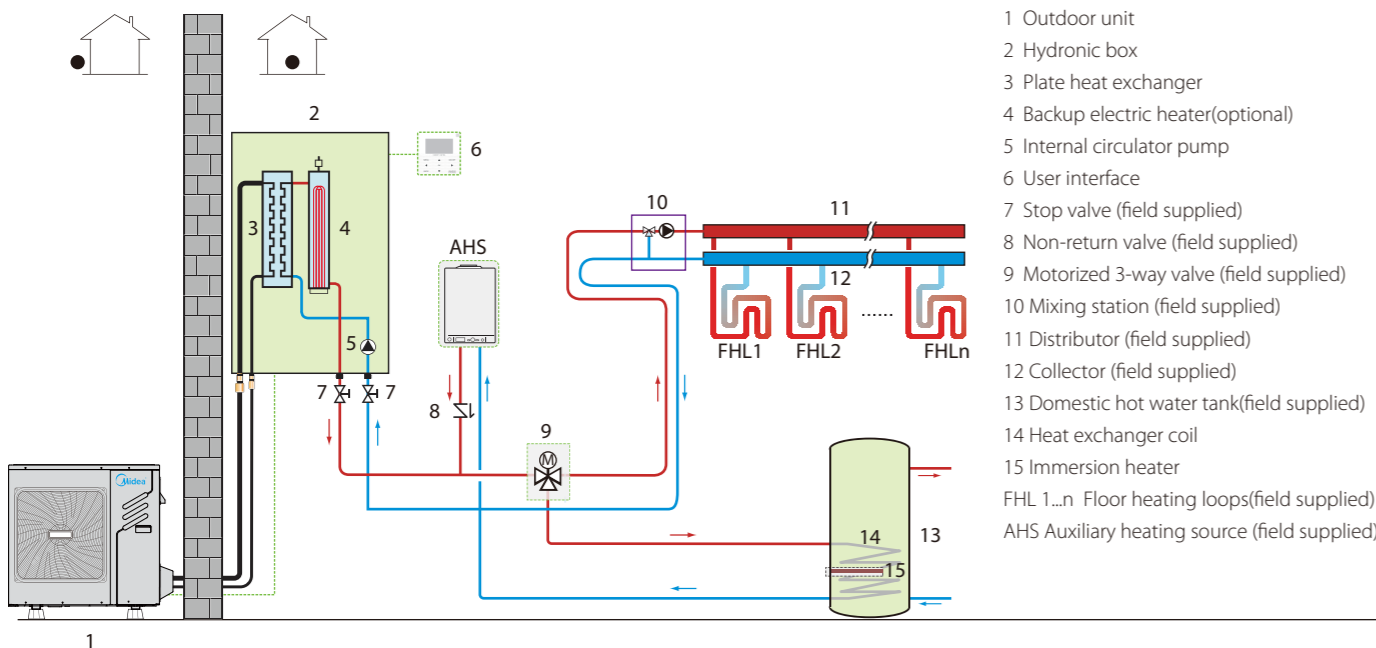

- 1 Outdoor unit
- 2 Hydronic box
- 3 Plate heat exchanger
- 4 Backup electric heater(optional)
- 5 Internal circulator pump
- 6 User interface
- 7 Stop valve (field supplied)
- 8 Non-return valve (field supplied)
- 9 Motorized 3-way valve (field supplied)
- 10 Mixing station (field supplied)
- 11 Distributor (field supplied)
- 12 Collector (field supplied)
- 13 Domestic hot water tank(field supplied)
- 14 Heat exchanger coil
- 15 Immersion heater
- FHL 1...n Floor heating loops(field supplied)
- AHS Auxiliary heating source (field supplied)

❖ **Application 6: Space Heating Through Floor Heating Loops and Fan Coil Units**

The floor heating loops and fan coil units require different operating water temperatures. To achieve these two set points, a mixing station is required. Room thermostats for each zone are optional.

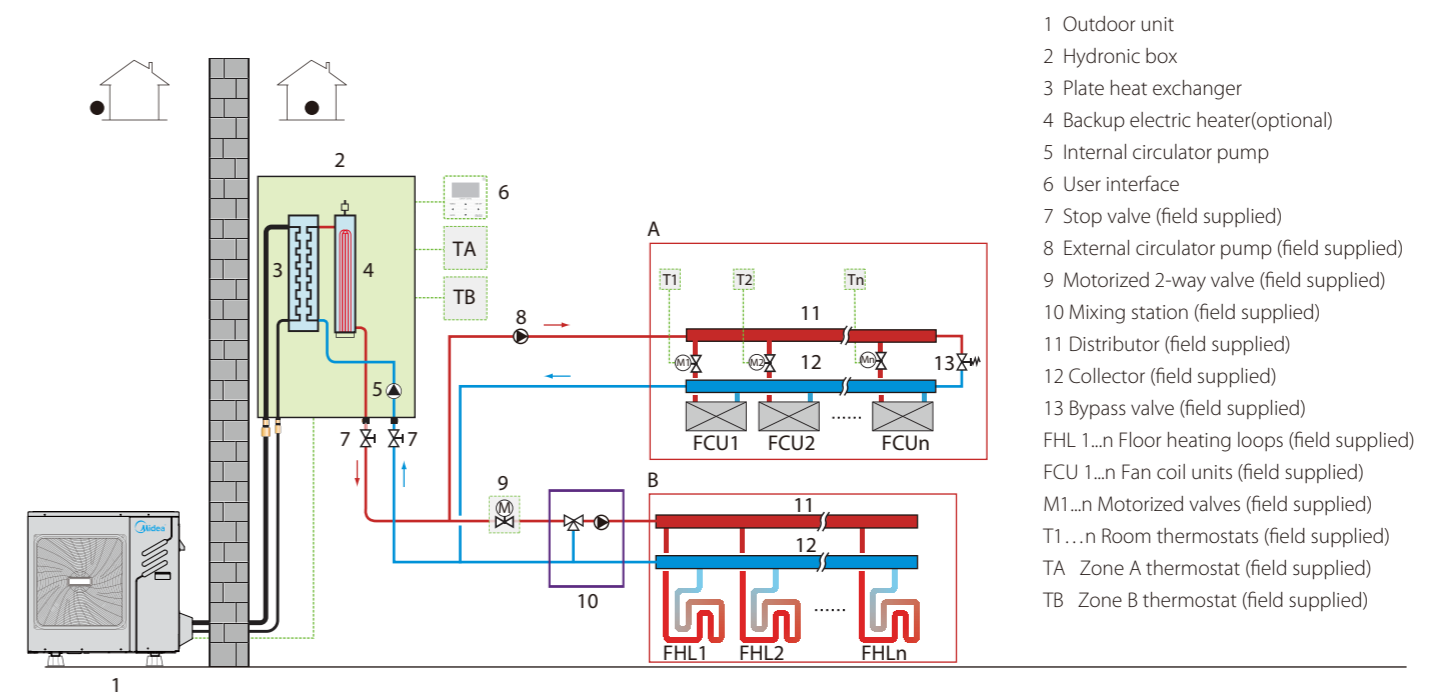

- 1 Outdoor unit
- 2 Hydronic box
- 3 Plate heat exchanger
- 4 Backup electric heater(optional)
- 5 Internal circulator pump
- 6 User interface
- 7 Stop valve (field supplied)
- 8 External circulator pump (field supplied)
- 9 Motorized 2-way valve (field supplied)
- 10 Mixing station (field supplied)
- 11 Distributor (field supplied)
- 12 Collector (field supplied)
- 13 Bypass valve (field supplied)
- FHL 1...n Floor heating loops (field supplied)
- FCU 1...n Fan coil units (field supplied)
- M1...n Motorized valves (field supplied)
- T1 ...n Room thermostats (field supplied)
- TA Zone A thermostat (field supplied)
- TB Zone B thermostat (field supplied)

❖ Application 7: Space Heating, Space Cooling and Domestic Hot Water Compatible with Solar Water Heater

Floor heating loops and fan coil units are used for space heating and fan coil units are used for space cooling. Domestic hot water is supplied from the domestic hot water tank connected to both the hydronic box and solar water heater. The unit switches to heating or cooling mode according to the temperature detected by the room thermostat. In space cooling mode, the 2-way valve is closed to prevent cold water entering the floor heating loops.

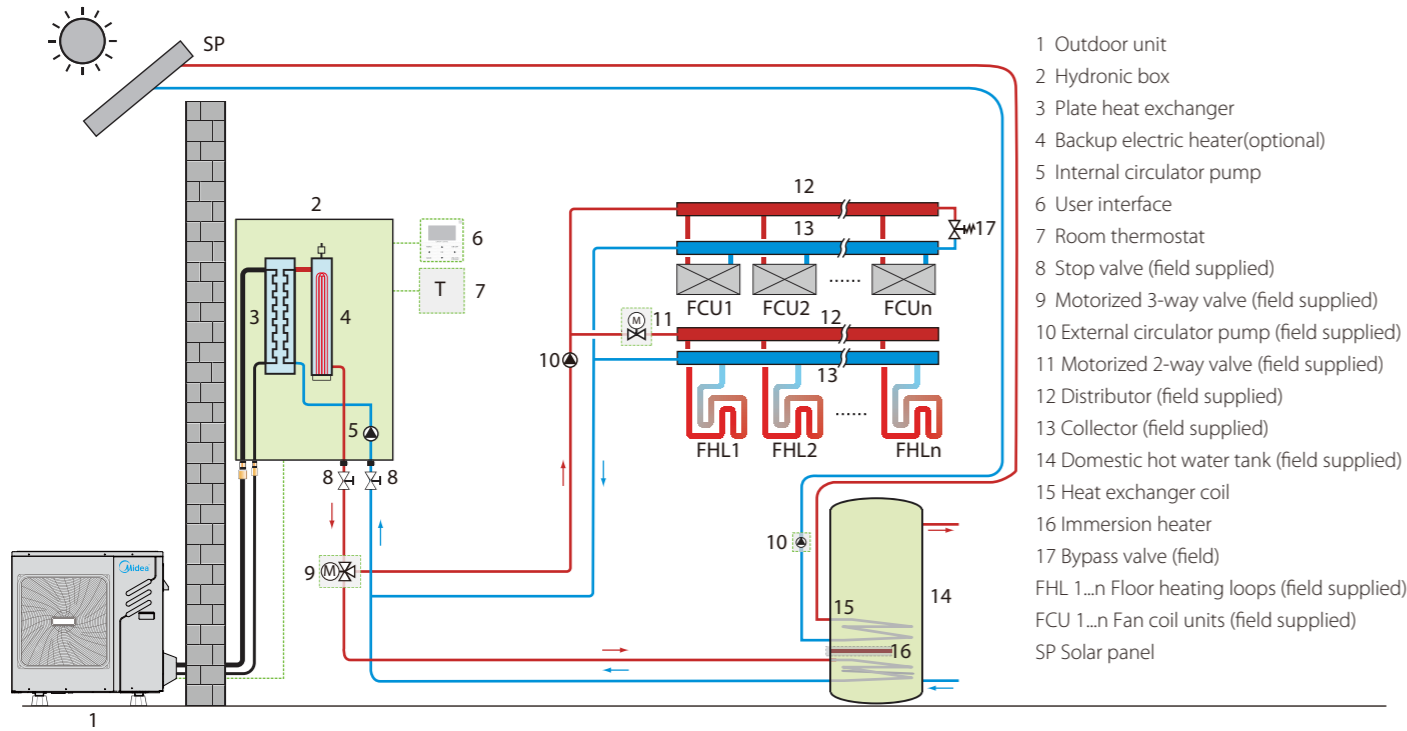

Specifications

M-Thermal Mono

Model name MHC-		V5W/D2N8	V7W/D2N8	V9W/D2N8	V12W/D2N8	V14W/D2N8	V16W/D2N8	V12W/D2RN8	V14W/D2RN8	V16W/D2RN8	
Power supply		220-240/1/50			220-240/1/50			380-415/3/50			
Heating ¹	Capacity	kW	4.65	6.65	8.60	12.30	14.10	16.30	12.30	14.10	16.30
	Rated input	kW	0.93	1.35	1.87	2.56	3.07	3.66	2.54	3.05	3.63
	COP		5.00	4.94	4.60	4.81	4.60	4.45	4.84	4.63	4.49
Heating ²	Capacity	kW	4.80	6.70	8.60	12.40	14.10	16.20	12.40	14.10	16.20
	Rated input	kW	1.33	1.88	2.50	3.52	4.06	4.72	3.45	3.99	4.70
	COP		3.60	3.57	3.44	3.53	3.47	3.43	3.59	3.54	3.45
Heating ³	Capacity	kW	4.65	6.80	8.60	11.90	14.20	16.10	11.90	14.20	16.10
	Rated input	kW	1.77	2.42	3.13	4.28	5.17	5.91	4.24	5.10	5.83
	COP		2.63	2.81	2.75	2.78	2.75	2.73	2.81	2.79	2.76
Cooling ⁴	Capacity	kW	4.60	6.45	8.00	12.20	14.00	15.50	12.20	14.00	15.50
	Rated input	kW	0.95	1.39	1.92	2.55	3.10	3.64	2.53	3.11	3.63
	EER		4.82	4.65	4.16	4.78	4.52	4.26	4.83	4.50	4.27
Cooling ⁵	Capacity	kW	4.85	6.30	7.95	10.90	12.90	13.80	10.90	12.90	13.80
	Rated input	kW	1.63	2.27	3.15	3.74	4.64	5.21	3.72	4.62	5.19
	EER		2.98	2.77	2.53	2.92	2.78	2.65	2.93	2.80	2.66
Seasonal space heating energy efficiency class ⁶	LWT at 35°C	class	A+++	A+++	A+++	A++	A++	A++	A++	A++	A++
	LWT at 55°C	class	A++	A++	A++	A++	A++	A++	A++	A++	A++
SCOP	LWT at 35°C		4.47	4.47	4.51	4.29	4.27	4.30	4.29	4.27	4.30
	LWT at 55°C		3.24	3.24	3.22	3.23	3.26	3.27	3.23	3.26	3.27
SEER	LWT at 7°C		4.71	4.99	4.92	4.85	4.73	4.54	4.85	4.73	4.54
	LWT at 18°C		7.61	8.58	7.88	7.50	7.16	6.78	7.50	7.16	6.78
Air flow	m ³ /h		3050	3050	3050	6150	6150	6150	6150	6150	6150
Sound power level ⁷	dB(A)		61	64	67	68	71	71	68	71	71
Sound pressure level ⁷ (1m)	dB(A)		48.8	52.3	54.5	57.6	58.0	58.1	57.2	58.1	59.0
Net dimensions (WxHxD)	mm		1210x945x402			1404x1414x405			1404x1414x405		
Packed dimension (WxHxD)	mm		1500x1140x450			1475x1580x440			1475x1580x440		
Net/Gross weight	kg		92/111			158/178			172/193		
Water piping connections Dia.	inch		1" Male BSP			1-1/4" Male BSP			1-1/4" Male BSP		
Safety valve set pressure	MPa		0.3	0.3	0.3	0.3	0.3	0.3	0.3	0.3	0.3
Expansion tank volume	L		2	2	2	5	5	5	5	5	5
Total water volume	L		2	2	2	3.2	3.2	3.2	3.2	3.2	3.2
Ambient temperature range	Cooling	C	-5-43			-5-46			-5-46		
	Heating	C	-25-35			-25-35			-25-35		
	DHW	C	-25-43			-25-43			-25-43		
LWT range	Cooling	C	5-25			5-25			5-25		
	Heating	C	25-60			25-60			25-60		
	DHW	C	40-60			40-60			40-60		
Refrigerant	Type		R32			R32			R32		
	Charged volume	kg	2.0			2.8			2.8		
Throttle type		Electronic expansion valve			Electronic expansion valve			Electronic expansion valve			
Backup electric heater	Standard mounted	kW	/	/	/	/	/	/	/	/	/
	Optional	kW	3	3	3	3	3	3	4.5	4.5	4.5
	Capacity steps		1	1	1	1	1	1	1	1	1

Notes:

- Evaporator air in 7°C, 85% RH, Condenser water in/out 30/35°C
- Evaporator air in 7°C, 85% RH, Condenser water in/out 40/45°C
- Evaporator air in 7°C, 85% RH, Condenser water in/out 47/55°C
- Condenser air in 35°C. Evaporator water in/out 23/18°C
- Condenser air in 35°C. Evaporator water in/out 12/7°C
- Seasonal space heating energy efficiency class testes in average climate general conditions.
- Sound power level and sound pressure level are the maximum value tested under the three conditions of Notes1, Notes3 and Notes5.
- The above data test reference standard EN14511; EN14825; EN50564; EN12102; (EU) No 811/2013; (EU)No 813/2013; OJ 2014/C 207/02:2014.

Abbreviations:

- DHW: Domestic hot water
- EWT: Entering water temperature
- LWT: Leaving water temperature

Operating Limits

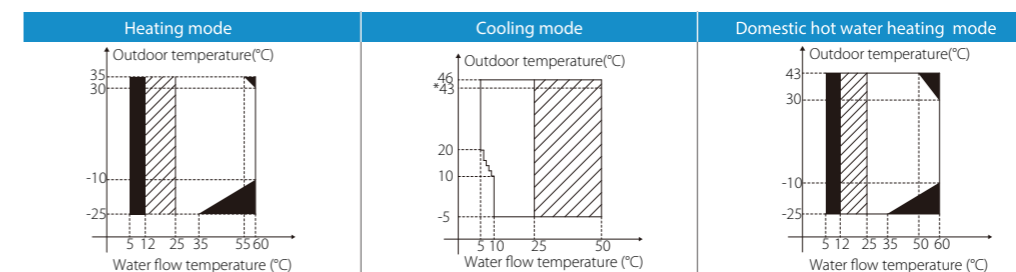

Abbreviations:
 T4: Outdoor temperature(°C)
 T1: Leaving water temperature (°C)

Notes:

- Shaded areas indicate no heat pump operation (backup electric heater or auxiliary heat source only)
- Hatched areas indicate water flow temperature drop or rise interval

*The maximum operating temperature of the 5/7/9kW model is 43°C

M-Thermal Split

Model name MHA-		V4W/D2N8	V6W/D2N8	V8W/D2N8	V10W/D2N8	
Power supply		V/Ph/Hz	220-240/1/50			
Heating ¹	Capacity	kW	4.20	6.50	8.40	10.0
	Rated input	kW	1.35	1.73	1.73	2.15
	COP		5.15	4.85	4.85	4.65
Heating ²	Capacity	W	4.20	6.35	8.05	9.85
	Rated input	W	1.15	1.74	2.16	2.72
	COP		3.65	3.64	3.73	3.65
Heating ³	Capacity	W	4.10	5.75	7.50	9.30
	Rated input	W	1.44	1.98	2.49	3.25
	COP		2.85	2.90	3.01	2.86
Cooling ⁴	Capacity	W	4.30	6.45	8.35	10.2
	Rated input	W	0.77	1.32	1.79	2.40
	EER		5.60	4.88	4.67	4.25
Cooling ⁵	Capacity	W	4.50	6.50	7.38	8.15
	Rated input	W	1.36	2.20	2.44	2.76
	EER		3.32	2.95	3.02	2.95
Seasonal space heating energy efficiency class ⁶	Water outlet at 35°C	class	A+++	A+++	A+++	A+++
	Water outlet at 55°C	class	A++	A++	A++	A++
Sound power level ⁷		dB(A)	61	62	63	65
Sound pressure level ⁸ (1m)		dB(A)	46.5	49.5	49.3	52.4
Net dimension (WxHxD)		mm	960x860x380		1075x965x395	
Packed dimension (WxHxD)		mm	1040x1000x430		1120x1100x435	
Net/Gross weight		kg	57/68		67/79	
Compressor	Type		Twin rotary invert		Twin rotary invert	
	Motor type		DC Brushless fan		DC Brushless fan	
Outdoor fan	Air flow	m ³ /h	3300		5000	
	Type		Fin-coil			
Pipe size O.D.	Liquid	mm	6.35		9.52	
	Gas	mm	15.88		15.88	
Connection method			Flared			
Between indoor and outdoor unit	Height difference	m	Max.20		Max.20	
	Pipe length	m	2-30		2-30	
Refrigerant	Type(GWP)		R32(675)			
	Charged volume	kg	1.55		1.65	
Additional refrigerant	Chargment	g/m	20		38	
	Min. pipe length	m	15			
Throttle type			Electronic expansion valve			
Outdoor air temperature range	Cooling	C	-5~43			
	Heating	C	-25~35			
	DHW	C	-25~43			

Notes:

- 1.Evaporator air in 7°C, 85% RH, Condenser water in/out 30/35°C
- 2.Evaporator air in 7°C, 85% RH, Condenser water in/out 40/45°C
- 3.Evaporator air in 7°C, 85% RH, Condenser water in/out 47/55°C
- 4.Condenser air in 35°C. Evaporator water in/out23/18°C
- 5.Condenser air in 35°C. Evaporator water in/out 12/7°C
6. Seasonal space heating energy efficiency class testes in average climate general
- 7.Evaporator air in 7°C, 85% RH, Condenser water in/out 30/35°C
8. Sound pressure level is the maximum value tested under the three conditions of Notes1, Notes2 and Notes3.
9. The above data test reference standard EN14511; EN14825; EN50564; EN12102; (EU) No811:2013; (EU) No:813:2013; OJ 2014/C 207/02:2014.

Abbreviations:
DHW: Domestic hot water
LWT: Leaving water temperature



Hydronic box

Hydronic box	Model		SMK-60/CGN8		SMK-80/CGN8	
	Compatible outdoor unit model names MHA-		V4W/D2N8	V6W/D2N8	V8W/D2N8	V10W/D2N8
LWT range	Space heating	Low	C	25 to 55		
		High	C	35 to 60		
	Space cooling	Low	C	5 to 30		
		High	C	18 to 30		
DHW	C	40 to 60				
Power supply	V/Ph/Hz	220-240/1/50				
Sound power level ⁷	dB(A)	43				
Sound pressure level ⁸	dB(A)	31.7				
Net dimension (WxHxD)	mm	400x850x427				
Packed dimension (WxHxD)	mm	495x1040x495				
Net/Gross weight	kg	47/53				
Water side heat exchanger		Plate type				
Water pump	Max. pump head	m	8.5			
Expansion vessel (Primary circuit)	Volume	L	5			
	Charge pressure	MPa	0.15			
Connection	Water side	mm	R1"			
	Refrigerant liquid	mm	6.35			9.52
	Refrigerant gas	mm	15.88			15.88
Safety valve		MPa	0.3			
Flow switch		m ³ /h	0.6			
Total water volume		L	2			
Backup E-heater	Standard mounted	kW	/			
	Optional	kW	3			
	Capacity steps		1			
	Power supply	V/Ph/Hz	220-240/1/50			

Notes:

- 1.Evaporator air in 7°C, 85% RH, Condenser water in/out 30/35°C
- 2.Evaporator air in 7°C, 85% RH, Condenser water in/out 40/45°C
- 3.Evaporator air in 7°C, 85% RH, Condenser water in/out 47/55°C
- 7.Evaporator air in 7°C, 85% RH, Condenser water in/out 30/35°C
8. Sound pressure level is the maximum value tested under the three conditions of Notes1, Notes2 and Notes3.

Abbreviations:
DHW: Domestic hot water
LWT: Leaving water temperature

Operating Limits

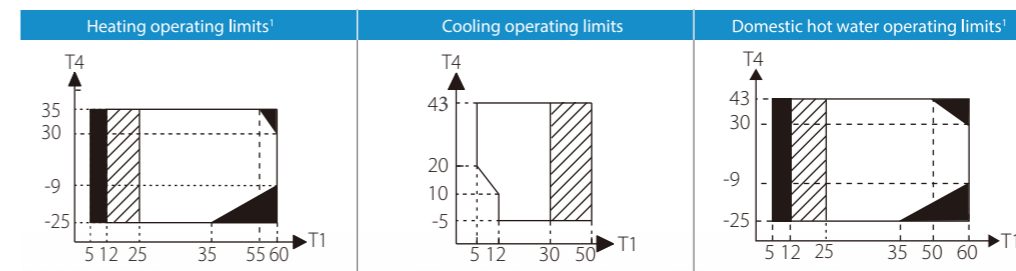

Abbreviations:
T4: Outdoor temperature(°C)
T1: Leaving water temperature (°C)
Notes:
■ Shaded areas indicate no heat pump operation (backup electric heater or auxiliary heat source only)
▨ Water flow temperature drop or rise interval

